

⚠ Read this handbook thoroughly and understand the whole information contained before trying to operate, inspect and service your machine!

**OPERATING &
MAINTENANCE
INSTRUCTIONS**

**VIBRATING
ROLLER**

**MODEL
HS66ST**

From HS66ST → VHS1 - 10101

SAKAI®

PREFACE

This operator's manual serves as a guide for the use of your Sakai HS66ST Vibrating Roller for those who are new to the machine, and also for the people who have experience in using the Machine and want to refresh their knowledge for the machine.

Read this manual thoroughly and try to fully understand the information before operating your machine. Keep this handbook at hand whenever you do your work.

The main subjects of this manual are:

(1) Basic precautions for safety, (2) Operation, (3) Daily maintenance and (4) Specifications. For operation and maintenance of the engine, refer to the Engine Instruction Manual furnished separately. Descriptions in this manual can differ from the machine instructions of your machine due to the results of the investigation and improvement in its design. If you have any inquiry regarding your Machine or this manual, contact our distributors.

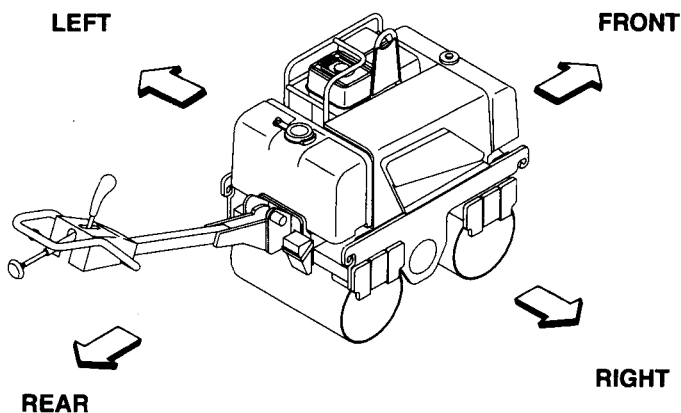

CONTENTS

CONTENTS

PREFACE

MACHINE AND ENGINE IDENTIFICATION NUMBERS	1
SAFETY NOTICES	2

1. BASIC PRECAUTIONS FOR SAFETY

1.1 General Precautions	4
1.2 Preparation for Safe Operation	6
1.3 Before Starting the Engine	7
1.4 After Starting the Engine	8
1.5 During operation	8
1.6 Loading and Unloading	10
1.7 Transportation	10
1.8 Handling the Battery	11
1.9 Before Servicing	12
1.10 During Servicing	14
1.11 Safety Decals	16

2. OPERATION

2.1 Instruments and Controles	19
2.1.1 Operator's station	19
2.1.2 Controles	20
2.2 Handling	23
2.3 Operation	24
2.3.1 Before starting up	24
2.3.2 Starting the engine	24
2.3.3 After starting the engine	26
2.3.4 Traveling	26
2.3.5 Stopping / parking	26
2.4 Vibratory Operation	28
2.5 General Rules for Operation	28
2.6 Operation of Unloader Valve	28
2.7 Operation of Sprinkler System	29
2.8 Adjustment of Scraper	29
2.9 Unloading the Steering Cylinder	30
2.10 Loading and Unloading	30
2.10.1 Use of a mobile crane	31
2.10.2 Self-propelling	31
2.11 After Loading the Machine	32
2.12 Operation in Cold Weather	32
2.12.1 Fuel oil and grease	32
2.12.2 Battery	32

2.13	After Operation	33
2.14	When the Cold Season is Over	33
2.15	For a Long Storage Period	34
2.16	During the Storage Period	34
2.17	When the Battery has Discharged	35
2.17.1	Connection and disconnection of booster cables	35
2.18	Prevention of Engine Trouble due to Water Entering Engine Cylinder (Measures against Water Hammer)	37
2.18.1	Preventive Measures against Water Entering	37
2.18.2	Inspection Prior to and Rules for Starting-Up the Engine:	37
3.	PERIODICAL MAINTENANCE	
3.1	Precautions.....	38
3.2	Walk-Around Checking.....	40
(1)	Every 10 hours (daily).....	40
(2)	Every 50 hours	41
(3)	Every 100 hours	42
(4)	Every 200 hours	45
(5)	Every 500 hours	46
3.3	Feeding Water and Lubricants.....	48
3.3.1	General rules	48
3.3.2	Capacity.....	48
3.3.3	Rating	48
3.3.4	Recommended lubrications	49
3.4	Electric Wiring Diagram	50
4.	SPECIFICATIONS	53

MACHINE AND ENGINE IDENTIFICATION NUMBERS

When ordering parts or making inquiries about your machine, the following information is requested:

(1) Machine model

Indicated on the dashboard in the operator's station.

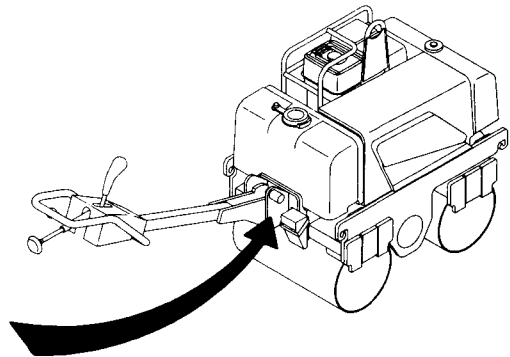

(2) Machine serial number

HS66ST ⇨ VHS1-○○○○○

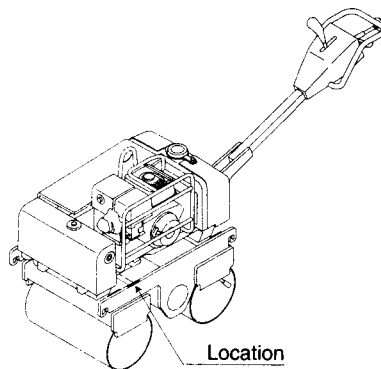

SAFETY NOTICES

For the safe use of your machine, correct handling and periodical maintenance are of utmost importance. Thoroughly read the safety precautions described in this manual. Do not attempt to operate and maintain your machine until you gain a full understanding of these safety statements.

This manual covers the proper and safe method of driving and handling of this machine for its intended use. When this machine is used a manner, other than that covered in this manual, you must assume responsibility for your own personal safety.

In this manual and on the machine, you will find safety notices. Each safety notice starts with a signal word as shown below:



Denotes that there is an extreme hazard. If you fail to take proper precautions, it is highly likely that you could be killed or seriously injured (The color of the symbol ▲ is red).



Denotes that there is a hazard. If you fail to take proper precautions, you could be killed or seriously injured (Symbol ▲ is orange).



Calls attention to safety practices. If you fail to take proper precautions, you could be injured or cause damage to the machine (Symbol ▲ is yellow).

It is almost impossible for the safety notices in this manual and or the machine to cover all the potential dangers. Keep alert to possible dangers not mentioned in this manual and on the decals.

 **WARNING**

Do not operate your machine before you read its operator's manual thoroughly.

Incorrect operation can kill or cause injury.

It is your responsibility to operate the machine safely.

- ☆ Non-approved modifications can pose safety-related problems. Before making any modifications, consult your distributor. For an injury or damage to the machine caused by non-approved modifications, Sakai accepts no responsibility.
- ☆ Basic precautions for safe operation of your machine are discussed beginning on page 4.
- ☆ To operate and work with your machine, you must be qualified.

▲ WARNING: Negligence of these instructions can lead to accidents.

1. BASIC PRECAUTIONS FOR SAFETY

1. BASIC PRECAUTIONS FOR SAFETY

1.1 General Precautions

■ Read thoroughly the operator's manual.

- Understand the functions of the controls and gauges. Familiarize yourself with their location and how to operate them. Understand the meaning of all the symbols.



■ Obey the worksite rules.

- Follow the worksite rules such as matters forbidden or to be attended to, and working procedures.

■ Wear protective clothing to suit the work.

- Wear clothing, safety shoes and hard hat to suit your work.
- Do not wear clothing and accessories that tend to get caught in the controls or protruded portions of the machine. Do not wear oily clothing.
- According to the type of jobs, wear safety goggles or mask.



■ Know the work area in advance.

- Know the terrain, geology and conditions of the road surface at the worksite. Start working after securing safety such as stationing a guardsman or putting up barriers where there is a risk of falling of the machine or collapse of shoulder.

■ Provide against an accident.

- Decide in advance the means of communication in an emergency. Know the location and use of an extinguisher and first-aid kit.

▲ WARNING: Negligence of these instructions can lead to accidents.

1. BASIC PRECAUTIONS FOR SAFETY

■ Know the capability of the machine.

- Thoroughly understand the performance of your machine and correctly operate the machine to meet the requirements of the job site. Operating the machine beyond its capabilities may lead to an accident. Use your machine within its capability.

■ Do not use a machine which has not been serviced correctly at regular intervals.

- Before working, perform necessary inspections. Start operation only after making certain the machine is in good operating condition. If found to be abnormal, report to the responsible person and have the fault corrected. Operate the machine after making sure that it is safe to operate.

■ Do not allow anyone to enter the work area except for authorized personnel.

- Always conduct the work paying attention to the workers around the machine.



■ Be careful of hot parts.

- After your machine has operated for some time, the coolant, engine oil and hydraulic fluid will become hot and the pressure will build up. If, in this state, you try to remove the filler caps, drain the oil or replace the filters, you can get burned. Perform this work in accordance with the correct procedures with the machine cooled down.
- To remove the radiator cap, slowly loosen the cap to relieve the pressure with the engine shut down and the coolant cooled down. (For the radiator cap with a lever, lift the lever to release the trapped pressure.)
- When removing the filler cap on the hydraulic tank, release the trapped pressure by turning it out slowly to prevent the oil from gushing out.
- Do not touch the muffler while the engine is running or immediately after it has been shut down. You can get burned.

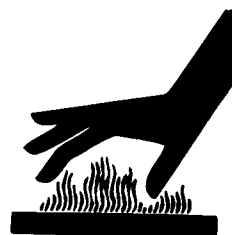

▲ WARNING: Negligence of these instructions can lead to accidents.

1. BASIC PRECAUTIONS FOR SAFETY

■ Be careful with fire.

- The fuel, oil, and anti-freeze will catch fire if open flames or ignition sources are used close to them. Particularly, the fuel is highly flammable.



- Do not smoke or use a match or cigarette lighter close to inflammables (combustibles).
- When refueling, stop the engine and do not smoke.
- The filler caps of the fuel and oil tanks must be kept tight.

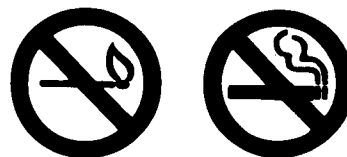

■ To handle the hydraulic fluid.

- Wear safety goggles to protect your eyes from contact with hydraulic fluid. It can irritate your eyes.



If the fluid contacts your eyes, flush with clean water for 15 minutes and get medical aid.

- The fluid can also irritate your skin. When handling it, wear rubber gloves to avoid contact with it. In case of skin contact, wash with soap and water.
- Be careful not to swallow the fluid. It can cause diarrhea and emesis.



If swallowed, do not try to vomit. Get medical help immediately.

1.2 Preparation for Safe Operation

■ Clean your machine.

- Do not place parts, tools or unnecessary articles on your machine.
- Keep the handholds free from muds, oil, ice or water, as they can cause slippage.

▲ WARNING: Negligence of these instructions can lead to accidents.

1. BASIC PRECAUTIONS FOR SAFETY

■ Inspect your machine before operation

- Check your machine for damage such as cracks and deformation. If found to be abnormal, operate the machine after taking a proper measure to secure safety.
- Check the level of fluids (fuel, engine oil, anti-freeze and hydraulic oil). Add as necessary.
- Check the area where the machine has parked for signs of leakage of oil, fuel and water. If any leakage is noticeable, determine the cause and make corrections immediately.

1.3 Before Starting the Engine

■ Before starting, make certain that each lever is in the neutral position and the parking lock is applied (parking lock lever in "LOCK" position).

■ When starting, secure safety around the machine.

- Before starting the engine. Make sure that parking lock has been actuated (parking lock lever is in "Lock" position).

■ Pay attention to ventilation.

- Exhaust fumes are dangerous if breathed in. When starting the engine in an enclosed area, provide good ventilation with windows and doors opened.

■ Do not stand close to the exhaust gas pipe opening.

- Exhaust fumes are noxious if breathed in.



1. BASIC PRECAUTIONS FOR SAFETY

1.4 After Starting the Engine

■ Secure safety around the machine.

- Ensure that the area around the machine is clear of personnel and obstructions.

■ Warm up the Engine

- Do not put your machine into motion immediately after the engine has started, let it idle for several minutes until it is at operating temperature.

■ Have a trial run.

- Make a test run in a safe place to check that there are no abnormal signs. If found to be abnormal, rectify the fault before traveling again.
- Listen for unusual sounds, and check for abnormal temperature rise. If abnormal, park the machine in a safe location and find the source of trouble before operating.

1.5 During Operation

■ Refrain from inattentive driving.

- Inattentive driving or driving relying on guess work can cause an accident. Use extreme care for workers present in the path of the roller or around it. In case of danger, stop and sound the horn, and proceed when the area is clear of personnel or obstructions.

■ When changing the direction of travel.

- secure the safety on the path in the travel direction. When travelling backward, exercise extreme care for people or obstructions.

■ At night, carefully drive the machine.

- Nighttime driving tends to frustrate the sense of distance. Carefully drive the machine at a speed suited to illumination. Keep the headlamps and flood lamps lighted. If necessary, provide extra lighting in the work area.

▲ WARNING: Negligence of these instructions can lead to accidents.

1. BASIC PRECAUTIONS FOR SAFETY

■ Repair as soon as possible if found to be defective.

- If the machine is found to be faulty, stop the machine and repair. Do not operate the machine until the problem is corrected. When any warning lamp indicates faulty operation, inspect the machine after moving it to the nearest safe location.

■ When parking.

- Select level and hard ground. If necessary to park on a slope, block the front of the drums on the downside of the slope.
- When required to park on the public road, provide necessary markings such as flag, barriers and illumination. However, be sure they do not obstruct traffic.
- Before leaving the roller, place Forward-reverse (F-R) lever in "Neutral" and parking lock lever in "Lock" position, then stop the engine.
- Remove the key from the ignition switch.

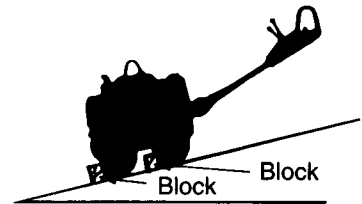

▲ WARNING: Negligence of these instructions can lead to accidents.

1. BASIC PRECAUTIONS FOR SAFETY

1.6 Loading and Unloading

- Loading and unloading can accompany any danger. Use extreme care.
- Select level and hard ground leaving a sufficient distance from the shoulder.
- Use sturdy ramps with proper width, length and thickness which allow safe loading and unloading. If they deflect considerably under load, apply wooden blocks to reinforce the ramps.
- To prevent your machine from crosswise slippage, keep the ramps free from oil, mud, debris, etc. The drum must also be free from extraneous matter that can cause slippage.
- Do not steer your machine on the ramps. If the machine is facing in the wrong direction, allow it to dismount from the ramps, correct the direction and try again.
- Do not use kinked, twisted or damaged wireropes for crane or winch operation. Use ones with ample strength.
- When lifting the machine, be sure to lift it vertically. Application of any lifting load to the hook in lateral or longitudinal direction, will be hazardous as it may bend or damage the hook.
- When loading is complete, fix the machine with wooden blocks placed under the drums and chains fastened to the machine.
- Do not use steering system while loading or unloading as it is extremely dangerous.

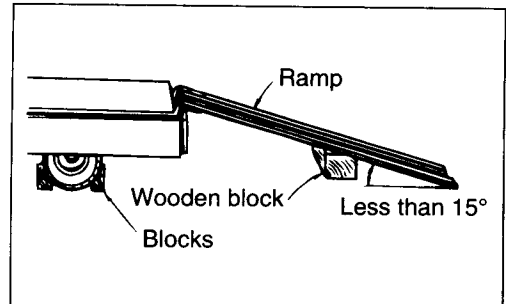

1.7 Transportation

- Follow required regulations.

▲ WARNING: Negligence of these instructions can lead to accidents.

1. BASIC PRECAUTIONS FOR SAFETY

1.8 Handling the Battery

Battery generates hydrogen gas which can explode. Do not allow any fire including lighted cigarette to approach or any action which may cause spark.

■ When handling the battery:

- Battery generates hydrogen gas which can explode. Do not allow any fire including lighted cigarette to approach or any action which may cause spark.
- Battery electrolyte contains sulphuric acid. It will destroy clothing and skin. If it touches your clothing or skin, flush with large quantities of water.
- In case of eye contact, flush with clean water and seek medical help.
- If swallowed, drink large amount of water, milk, beaten egg or vegetable oil, and get medical help.
- Wear safety goggles when handling the battery. Wear safety goggles, full face shield, rubber gloves and rubber apron when adding fluids to the battery.
- The battery generates flammable gases that can cause an explosion. Do not smoke close to the battery. Keep the battery away from flames, sparks and ignition sources.



- Inspect or handle the battery with the engine shut down and the starter key in the OFF position.
- Keep metallic items such as tools away from the battery terminals.
- Loose terminals can cause sparks leading to an explosion. Secure the terminals tightly.
- Battery is for only starting this machine. Do not use it for any other purpose.
- Do not use or charge the battery with its electrolyte level remaining below the "Lower" mark (minimum electrolyte level) .

Continuing the use with the level remaining below "Lower" mark accelerates deterioration of the battery internals, not merely shortening its useful life, even causing an explosion. Immediately replenish with distilled water so it comes to between the Upper and Lower levels.

▲ WARNING: Negligence of these instructions can lead to accidents.

1. BASIC PRECAUTIONS FOR SAFETY

■ Jump-starting the engine.

- Before starting up, make sure that Forward-reverse (F-R) lever is in Neutral and starting switch is in OFF position respectively, and engage blocking.
- Wear safety goggles when jump-starting the machine.
- When starting from another machine, do not allow the two machines to make contact with each other.
- When connecting the battery cables, start with the positive terminal. For disconnection, start with the negative one.
- Do not allow a tool to bridge between the positive terminal and machine body. This can generate dangerous sparks.
- Do not connect the booster cable to wrong terminal. NEVER connect the positive terminal to the negative.
- Final connection to the engine block of the disabled machine can cause sparks. The connecting point should be as far as possible from the battery.

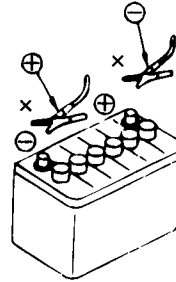

1.9 Before Servicing

■ Post a warning tag during inspection or servicing

- Starting the engine or touching any lever inadvertently by any third person while the roller is under inspection or in service may lead to serious personal accident.
- Attach the warning tag at an conspicuous position on the control handle. If necessary, post it additionally around the roller as well.



■ Use proper tools.

- It is very dangerous to use damaged or deteriorated tools or to use tools for other purposes than intended. Use correct tools for their intended use only.



▲ WARNING: Negligence of these instructions can lead to accidents.

1. BASIC PRECAUTIONS FOR SAFETY

■ Change safety-related parts at regular intervals.

- Replace fuel hose and high pressure hydraulic hoses regularly to prevent fire. Replace high pressure hoses of the power steering system every two years.
 - ☆ Change these parts at regular intervals even if found to be normal. They will deteriorate as time goes on.
 - ☆ Change any hose found to be abnormal even if it is within its recommended service interval.

■ With the Forward-reverse (F-R) lever placed in Neutral, apply parking brake and engage blocking.

■ Inspect or service your machine with the engine stopped.

- Use extreme care when servicing the machines with the engine running such as cleaning inside of radiator.
- One man should always be ready to stop engine. Use care not to touch any lever unless it is necessary. Service personnel should use care to prevent any part of his body or clothing from being caught by moving parts.

■ Supplying fuel and oils

- Spilled fuel or oil will be slippery. Wipe up immediately. Keep the filler caps tight. Do not use fuel for flushing oil. Handle fuel and oil in a well ventilated area.

■ Check the coolant level in the radiator.

- To check the coolant level, shut down the engine and allow the engine and radiator to cool down.

■ Illumination

- For inspecting the level of the fuel, oil, coolant and battery electrolyte, use burn-proof illuminations. Failure to use this type of illumination can result in an explosion.



1. BASIC PRECAUTIONS FOR SAFETY

1.10 During servicing

■ Keep unauthorized persons away

- During service, do not allow persons not concerned to enter the work area, particularly when grinding or welding operation is performed or heavy hammers are being used.



■ Keep your machine clean

- Spilled oil, grease or scattered debris are dangerous. Always keep your machine clean. Moisture that penetrates into the electrical system can cause malfunctions. Do not use water to clean sensors, connectors and the operator's station.

■ When repairing the electrical system

- For repairing the electrical system or for conducting welding, disconnect the negative cable from the battery to shut off the electricity.



■ Carefully handle high pressure hoses.

- Do not try to bend or hit hoses against a hard object. Do not use hoses or pipes that are bent or damaged. They will burst.
- Replace damaged fuel hose and hydraulic hoses. An oil or hydraulic fluid spill can cause a fire.

▲ WARNING: Negligence of these instructions can lead to accidents.

1. BASIC PRECAUTIONS FOR SAFETY

■ Be careful of high pressure hydraulic fluid.

- Bear in mind that the working equipment hydraulic systems are under internal spressure. Do not perform adding, draining, inspection or servicing of the hydraulic systems until the internal pressure has been relieved. Hydraulic fluid leaking through a fine hole at high pressure can penetrate your skin and eyes. Inspect leakage by holding a hard board close to suspected leaks wearing goggles. If affected by high pressure oil, get medical help immediately.

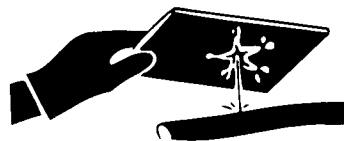

■ Be careful of hot parts

- After the machine has been operated for some time, the coolant, engine oil and hydraulic fluid will become hot.
- Removing the radiator cap or draining the coolant or oil can burn you. Perform this work in accordance with correct procedures after the systems have cooled down.

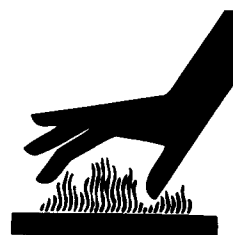

■ Use care when inspecting or servicing fan or belts in motion

- Secure loose clothing and keep articles away that could get caught in moving parts.
- Do not let your body or tools make contact with the fan blades or belts. They can be cut seriously.

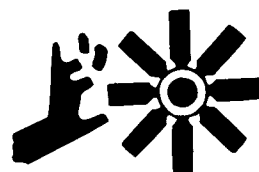

■ Used oil disposal

- Do not throw used oil into a drain or waterway. Drain the oil from the machine into a proper container. Do not drain directly on the ground.
- Obey all local, state and federal environment regulations for the proper disposal of oil, fuel, coolant, battery electrolyte or any other fluids.

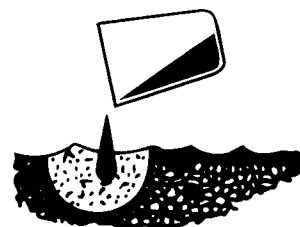

▲ WARNING: Negligence of these instructions can lead to accidents.

1. BASIC PRECAUTIONS FOR SAFETY

1.11 Safety Decals

Keep all decals clean. If lost, replace with new one. There are decals other than those shown below: Treat them in the same manner as the one shown here.

① 1472-19018-0

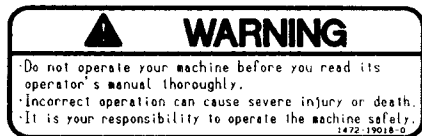

② 3998-16490-0

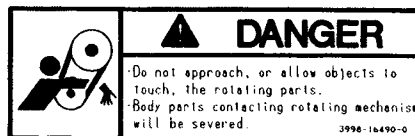

③ 1472-19017-0

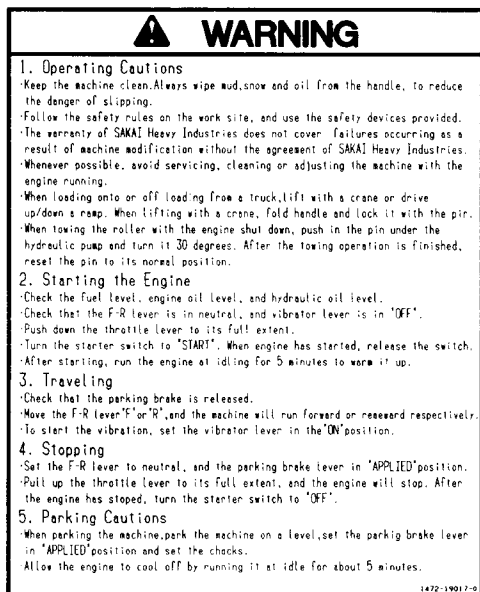

④ 1472-19019-0

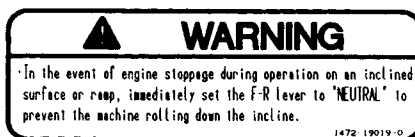

⑤ 1472-19009-1

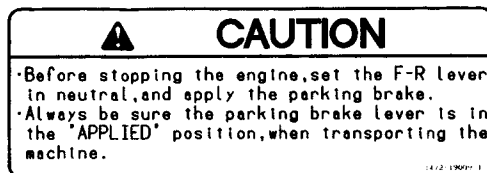

▲ WARNING: Negligence of these instructions can lead to accidents.

1. BASIC PRECAUTIONS FOR SAFETY

= HONDA engine mounted models =

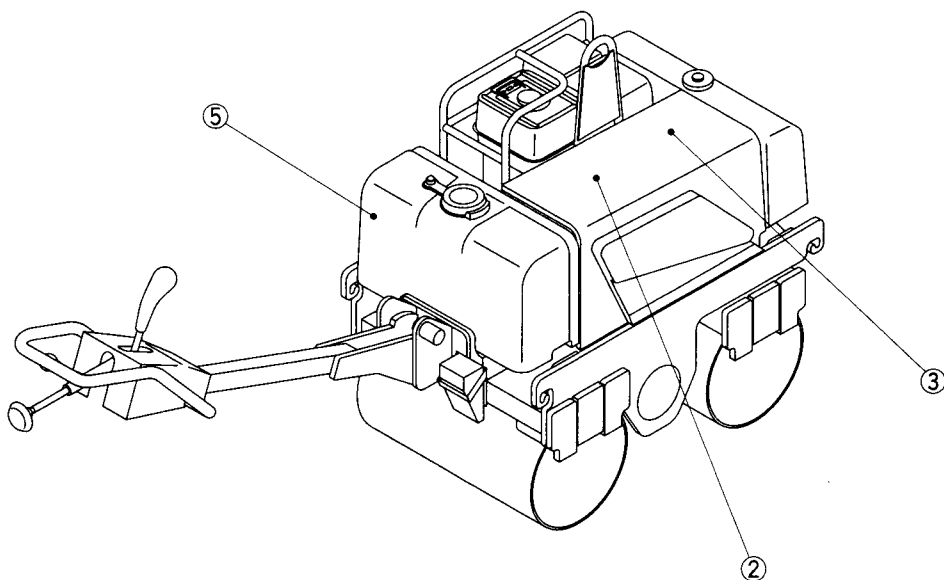
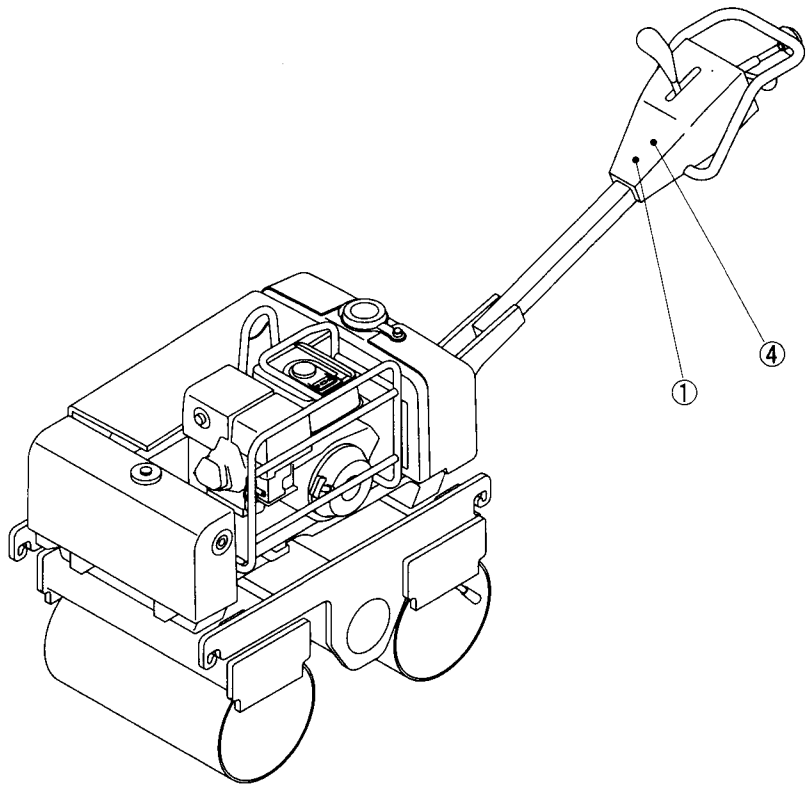

▲ **WARNING:** Negligence of these instructions can lead to accidents.

1. BASIC PRECAUTIONS FOR SAFETY

= KUBOTA and YANMAR engine mounted models =

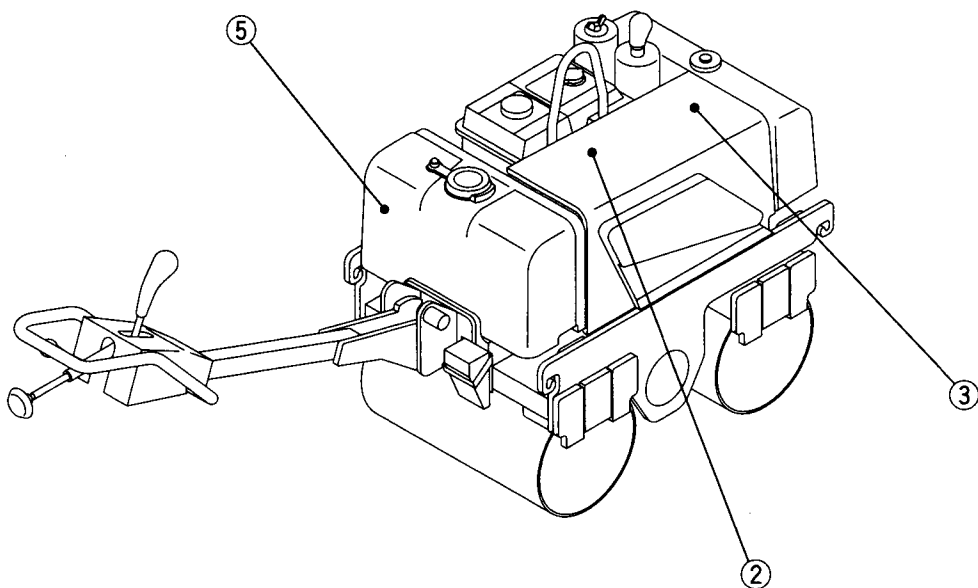
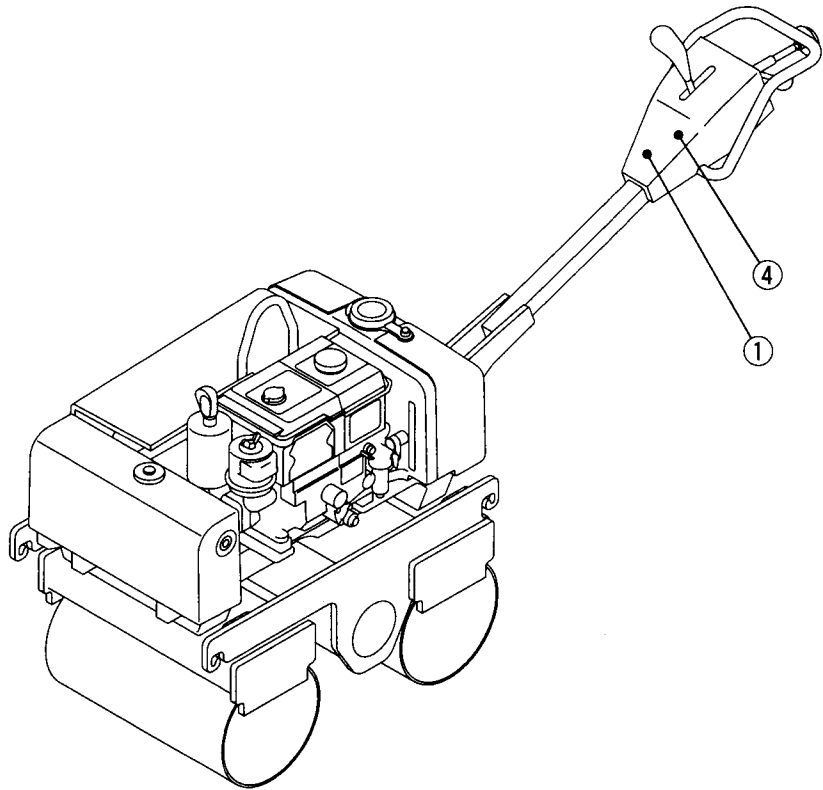

2. OPERATION

2.1 Instruments and Controls

2.1.1 Operator's station

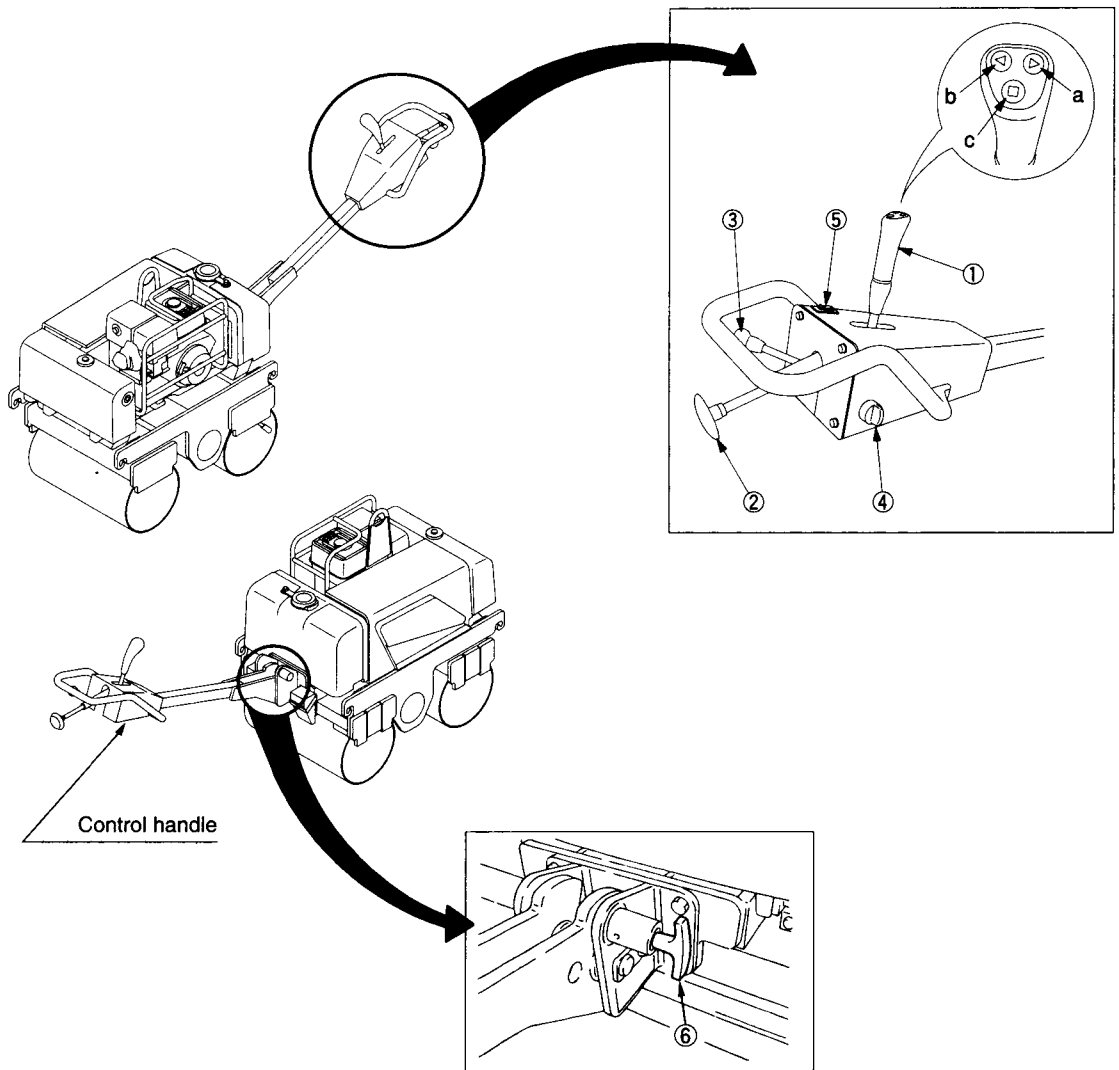

- ① Forward-reverse (F-R) lever
 - a. Steering switch (right)
 - b. Steering switch (left)
 - c. Horn switch
- ② Safety system knob

- ③ Throttle lever
- ④ Starter switch
- ⑤ Vibrating switch
- ⑥ Control handle lock pin

2. OPERATION

2.1.2 Controls

Acquaint yourself with the function of required controls and carry out safe operation.

Forward-reverse lever

This has three functions; Starting (forward or reverse), stopping and speed changing steplessly. Moving the lever forward or reverse causes the roller to travel accordingly and placing it in neutral position causes the roller to stop.

NOTE: Traveling speed is in proportion to the angle of lever tilted.

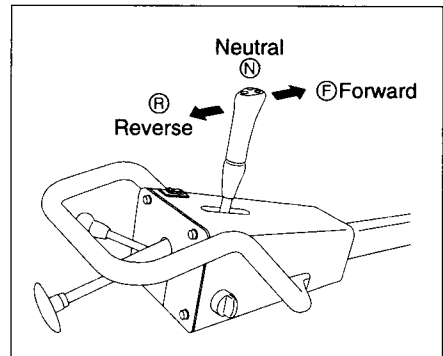

IMPORTANT

- Do not operate the vibrator on a hard area such as cement concrete pavement surface or the ground covered by thick steel sheets.
- Keep the vibrator stopped when the machine is at rest.
- Shut off the vibrator immediately when the machine has been caught in the mud during vibratory operation.

Steering Switch

Steering control is effected by means of switches located at upper part of forward travel lever. Lightly pushing the right side switch causes front drum to turn to right and, rightly pushing the left side switch causes the front drum to turn to left. For traveling straight, pushing the left and right switches quickly and lightly, allows you to make fine adjustment.

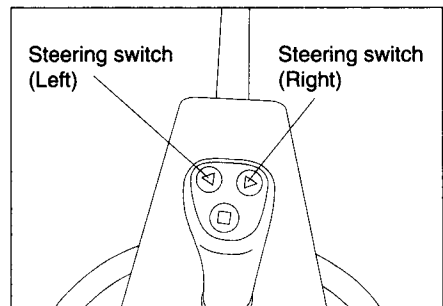

Horn

Pushing the switch in front of steering switch lightly causes the horn to sound.

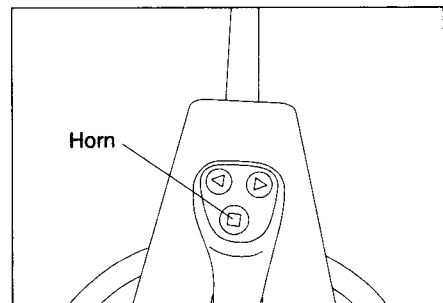

Vibrating switch

- (1) Vibration is generated when switch is set to the ON position.
- (2) Vibration is shut down if set to the OFF position.

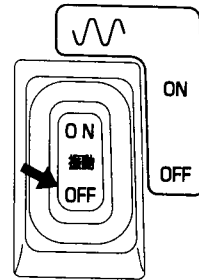

Safety system knob

When depressed, it causes the roller to travel forward at very slow speed.

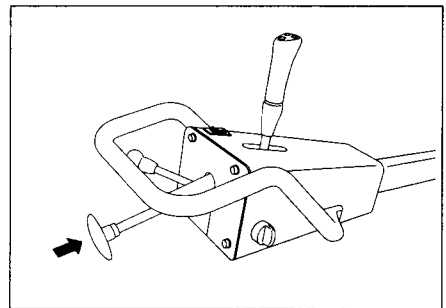

Starter switch

Starts and stops the engine

= HONDA and YANMAR engine mounted models =

- OFF** : The key can be removed in this position. All the electric systems are switched off. To shut down the engine, move the key to this position.
- ON** : The charging circuit and lamp circuit are charged with electricity. Let the key stay in this position after the engine has started.
- START**: The engine is cranked and gets started. The moment the engine has started, release the key. It will automatically return to the ON position.

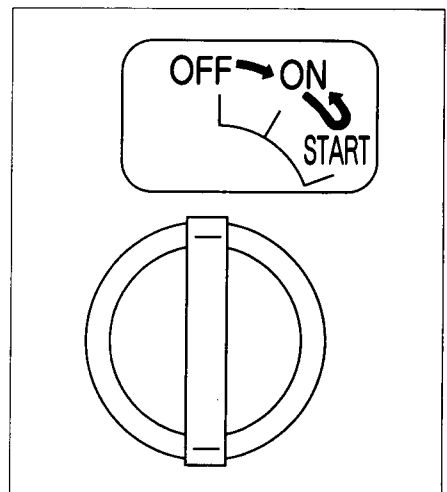

2. OPERATION

= KUBOTA engine mounted roller =

HEAT : When the engine is cold, hold the starter switch in the HEAT position for about 10 seconds. The key will automatically return to the OFF position. Turn the key to the START position to start the engine.

OFF : The key can be removed in this position. All the electric systems are switched off. To shut down the engine, move the key to this position.

ON : The charging circuit and lamp circuit are charged with electricity. Let the key stay in this position after the engine has started.

START: The engine is cranked and gets started. The moment the engine has started, release the key. It will automatically return to the ON position.

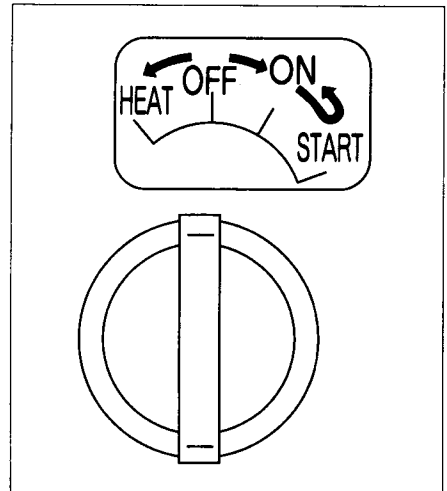

IMPORTANT

After removing the key switch, use the provided cover over the starting switch.

Horn switch

Horn sounds with the horn switch pressed.

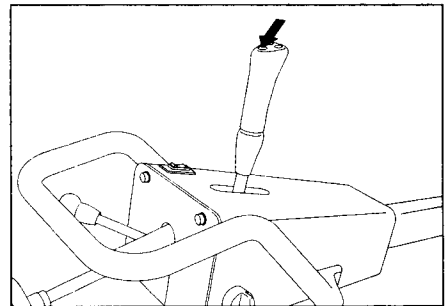

IMPORTANT

Horn is operative with the starter switch in the ON position.

Throttle lever

Shifts the engine RPM.

The engine RPM increases when moved toward the operator.

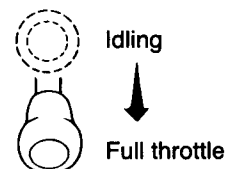

IMPORTANT

Changing the maximum engine rpm can be a cause of trouble.

2.2 Handling

Control handle

Can be folded for transportation.

1) To fold the control handle:

With the lock pin pulled back to release the lock, lift the control handle.

When the handle is in fully folded position, the pin automatically locks the handle.

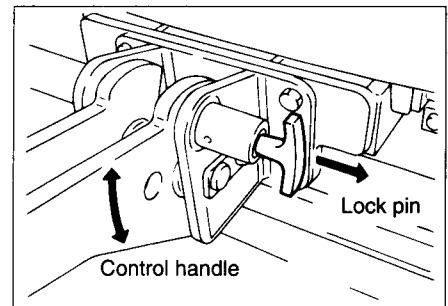

2) To set the control handle to the operating position:

With the lockpin pulled back to release the lock, swing down the control lever till it comes to the operating position. The lever is automatically locked there.

⚠ CAUTION

After folding or shifting the position of control handle, make sure that it is positively locked.

Parking lock lever

For parking, place the parking lock lever in "LOCK" position.

If the lever is difficult to operate, try to move the roller slightly forward or reverse. For traveling, be sure to return the lever to "UNLOCK" position.

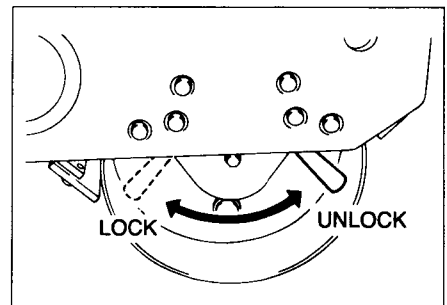

NOTE: If the parking lock lever is hard to lock, propel the machine slightly forward or backward.

⚠ WARNING

- When parked, it is absolutely important that the parking lock lever is in "LOCK" position.
- Never shift the lever to "LOCK" position while the roller is in motion (Do not use it for a service brake).

2. OPERATION

Steering lock

When you are not using the steering system, lock the steering wheel by means of lock pin located at front of the roller. Use spring pin for retaining the lock pin.

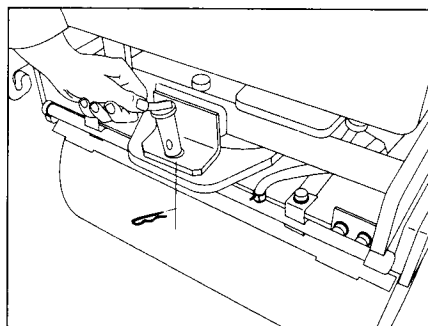

2.3 Operation

2.3.1 Before starting up

Make sure that F-R lever is in neutral, vibration switch in "OFF" and make sure that parking lock lever is in "Lock" position.

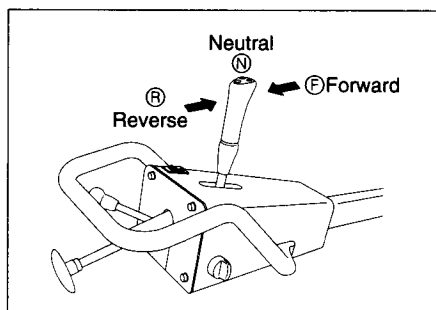

Forward-reverse (F-R) lever

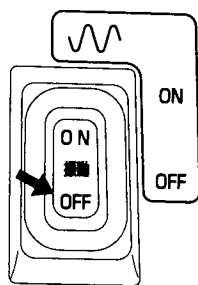

Vibrating switch

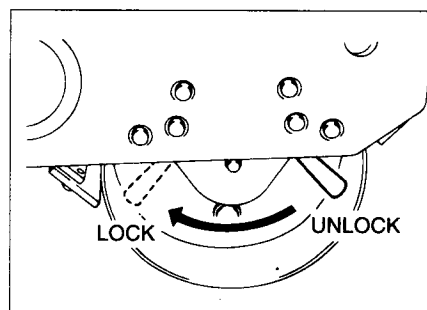

Parking lock lever

⚠ WARNING

- Make sure that there is no obstruction around, before starting up.
- Be sure to place the Forward-reverse (F-R) lever in Neutral before starting up.

2.3.2 Starting the engine

(1) Place fuel cock in "O" (open) position.

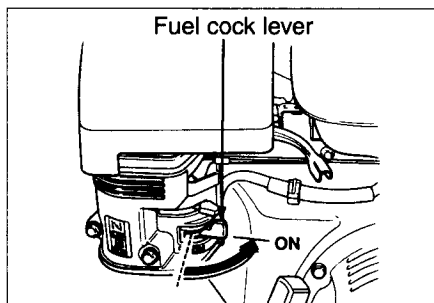

HONDA engine mounted models

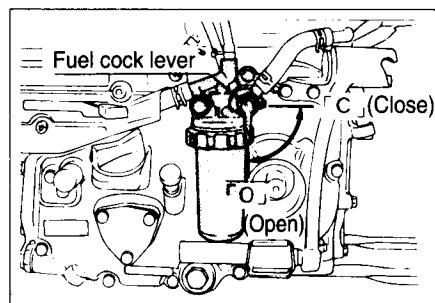

KUBOTA and YANMAR engine mounted models

IMPORTANT

Placing the fuel cock in "O" position causes automatic air bleeder to actuate to remove residual air from piping or filter. Wait for 20 seconds before starting the engine.

2. OPERATION

- (2) To start a cold engine, move the choke lever to the CLOSED position. (HONDA engine mounted models)

To restart a warm engine, leave the choke lever in the OPEN position.

Some engine applications use a remotely-mounted choke control rather than the engine-mounted choke lever shown here.

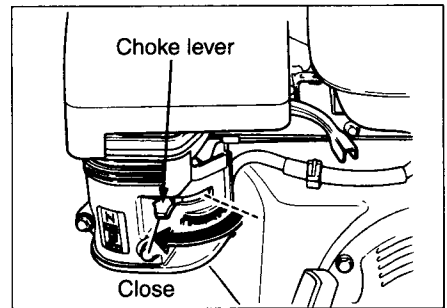

- (3) Depress the throttle lever away from the SLOW position, about 1/3 of the way toward the FULL position. (HONDA engine mounted models)

Depress throttle lever all the way down. (KUBOTA and HONDA engine mounted models)

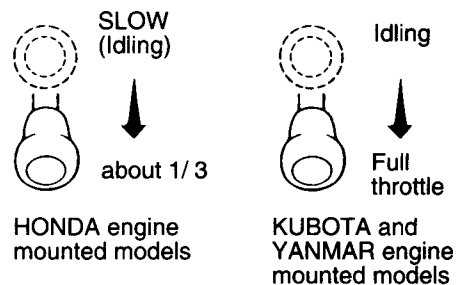

- (4) With starter switch turned to "ON", make sure that oil pressure warning buzzer sounds. If not, locate the cause to correct it. (KUBOTA and HONDA engine mounted models)

- (5) If engine is cold, preheat it for about 10 minutes (Applicable to KUBOTA engine mounted.)

- (6) Turning starter switch to "Start" position causes engine to start. Releasing the switch as it starts, causes the switch to move back to (ON) position automatically.

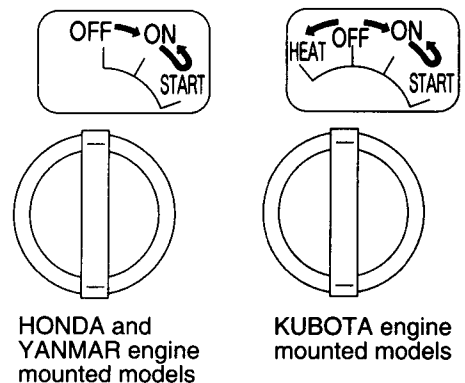

⚠ CAUTION

- In order to remove water that has entered on a rainy day or after carwash, use the decompression lever for manual cranking before starting the engine. (Refer to the "Engine Operation Manual" for the manual cranking operation.)
- After engine has started, try not to turn the starter switch.
- If oil pressure warning buzzer continues to sound after engine has started, stop the engine immediately and check the level of engine oil.
- Do not operate starter motor continuously any more than 15 seconds.
- If engine fails to start, allow an interval of 30 seconds or longer.

2. OPERATION

2.3.3 After starting the engine

After starting, do not operate the roller immediately but observe following:

- 1) Warm up the engine for a few minutes.
- 2) Make sure that color of exhaust is normal and no abnormal noise or odor is noticed.

2.3.4 Traveling

⚠ WARNING

**Before starting to travel, make sure that there is no one around your roller.
When travelling backward exercise extreme care for people or obstructions.**

- (1) Place parking lock lever in "UNLOCK" position.

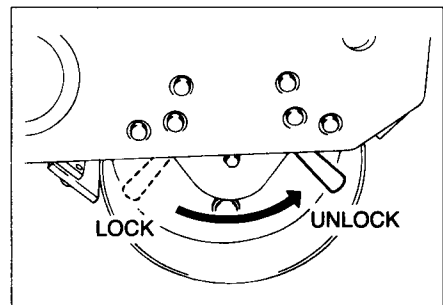

- (2) Tilting the forward-reverse lever forward or backward, causes your roller to travel accordingly. Be sure to operate the lever slowly.

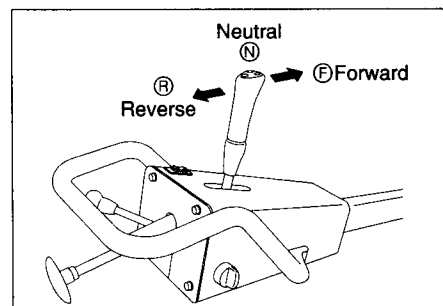

⚠ CAUTION

Be sure to operate the lever slowly.

2.3.5 Stopping / Parking

⚠ WARNING

- Avoid parking on a grade.
- If necessary to park on a grade, block the wheel to prevent unexpected moving down the grade.
- When leaving from the machine, stop the engine and lock the parking lock lever. Remove the starter key.
- After removing the key, apply cover to the starter switch.

2. OPERATION

- (1) Placing the forward-reverse lever in neutral position causes your roller to stop.

⚠ CAUTION

Normal stopping should be made by means of forward-reverse lever.

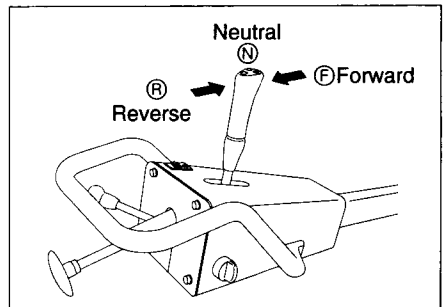

- (2) Place parking lock lever in "LOCK" position.

⚠ CAUTION

The alarm buzzer will sound when the lever is set in the forward or backward position.

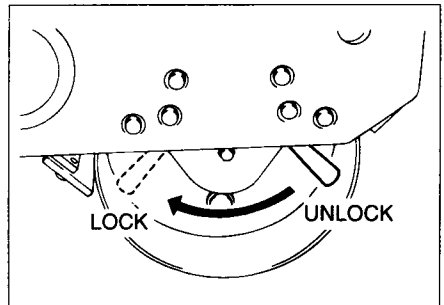

- (3) Run the engine unloaded at idling speed for 2 to 3 minutes.
- (4) Returning the throttle lever to the "SLOW" position.
- (5) Turn the starter switch to the "OFF" position.
- (6) Place fuel cock to "CLOSE" position.
- (7) Turn the starter switch to "OFF" position.

⚠ WARNING

When the engine stops on a slope, return the forward/backward lever to the neutral "N" position, and set the parking lock lever in the "LOCK" position to prevent an accident due to the falling of the machine by its own weight.

⚠ CAUTION (KUBOTA and YANMAR engine mounted models)

- Try not stop engine with decompression lever. It may cause trouble in valve system.
- If anti-freeze is not added during cold climate, be sure to drain radiator completely when engine is cooled after work.
- Do not turn starter switch OFF while engine is running or before it comes to a complete stop.

2. OPERATION

2.4 Vibratory Operation

- (1) Vibration is generated when switch is set to the ON position.
- (2) Vibration is shut down if set to the OFF position.

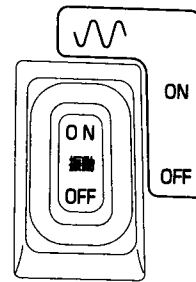

⚠ WARNING

Set the F-R lever to the neutral position when the engine has stopped.

Unexpectedly during the vibratory operation on a slope. This prevents the roller from creeping down the slope.

IMPORTANT

- While the roller is standing still, do not engage vibration.
- If stranded in mire during compaction work, stop the vibration immediately.

2.5 General Rules for Operation

- (1) While traveling, have the control handle pin locked completely.
- (2) Before lifting up your roller, make sure that handle is folded and locked with pin.
- (3) For parking on slope, in addition to locking the parking lock lever, engage appropriate block to drums.

2.6 Operation of unloader valve

For towing your roller with engine stopped, operate unloader valve in the following manner (Unloader is located underneath hydraulic pump):

[For towing] (Unloaded)

With the unloader valve control pin pressed upward, rotate it 30 degrees clockwise or counter clockwise to lock the spool.

[For normal travel] (Loaded)

With upward force applied to the control pin, rotate it and return it to original position so that the pin will come out.

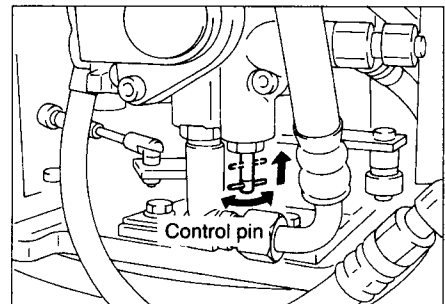

⚠ WARNING

On a slope, chock the wheels and use extreme care when handling the unloader lever and towing the machine.

2.7 Operation of Sprinkler System

IMPORTANT

- Before starting sprinkler, check the level of water in tank and top up as necessary.
- Be sure to always use fresh water for sprinkling operation.

CAUTION

- In cold climate, drain water completely after work to prevent freezing.

Turning sprinkler cock to "OPEN" position allows sprinkling operation to start.

[Draining procedure]

- (1) Remove drain cap off the tank to permit to drain.
- (2) Turn cock to "OPEN" position to drain the hose.

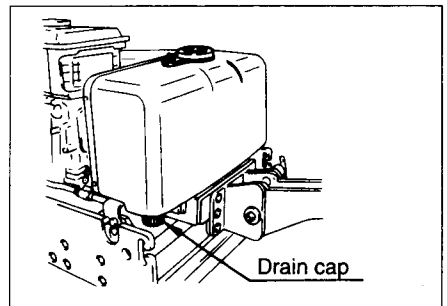
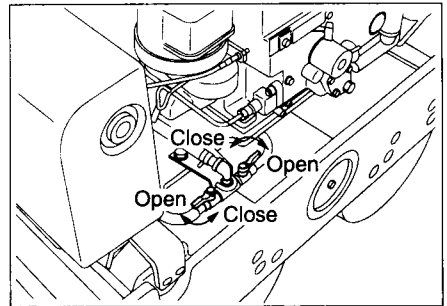

2.8 Adjustment of Scraper

Loosen blade mounting bolts (A) and adjust the clearance of scraper blade to 2mm, before tightening the bolts again.

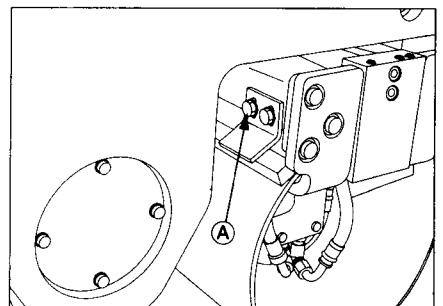
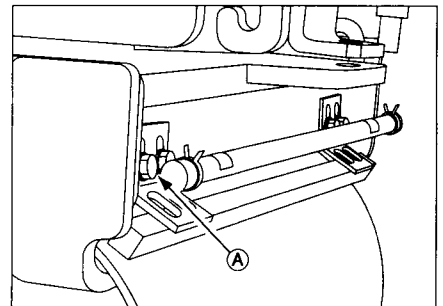

2. OPERATION

2.9 Unloading the Steering Cylinder

If there is any kind of trouble in hydraulic or electric circuit of steering system and you want to control steering angle manually, follow the procedure below.

- (1) Make sure that engine has been stopped and key switch is in OFF position.
- (2) Remove hood cover.
- (3) Push the unload valve of steering solenoid, by means of an appropriate rod.
- (4) While keeping the unload valve depressed, move the roll on the steering side, using a bar or the like as a fulcrum.

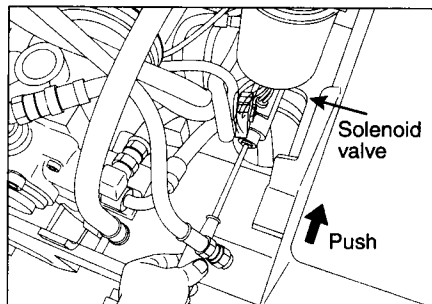

2.10 Loading and Unloading

▲ WARNING

- Use sturdy ramps with proper width, length and thickness which allow safe loading and unloading.
- If the ramps deflect considerably under load, apply wooden blocks to reinforce them.
- Loading should be conducted on a level and hard ground. Leave a sufficient distance between the machine and the shoulder.
- To prevent slippage on the ramps, keep the drums free from mud, oils, etc. The ramps must also be free of grease, oil and ice.
- Do not steer the machine on the ramps. If the machine is facing in the wrong direction, allow it to dismount from the ramps and correct the direction.
- If the engine stops while self-propelling on the rumps for loading or unloading, return the F-R lever to the neutral position immediately. Failure to do so will cause the roller to creep down the rumps.
- Steering action during loading or unloading is hazardous and should be prohibited.

For loading and unloading, use ramps or a proper loading stand.

2.10.1 Use of a mobile crane

- (1) Before lifting the roller, check the mobile crane in accordance with the specified check list.
- (2) Check the lifting wire ropes to see if they are in good condition and have enough capacity to lift the roller.
- (3) When lifting, set the stabilizer of the crane on the planking speed under it.
- (4) The truck driver who transports the roller must make sure that the parking brake of his truck is applied positively and all tires are chocked.
- (5) When lifting, the crane operator and other workers must strictly obey hand signals.
- (6) Fold the control handle.
- (7) Engage the wires to the lifting hook of the roller. Conduct loading or unloading slowly keeping the machine well-balanced.
- (8) Perform loading or unloading slowly being careful not to allow the roller and wire ropes to touch obstructions.
- (9) Load the machine in the correct position on the truck bed.

⚠ WARNING

Be careful not to allow hook or wire rope of crane to come in contact with folded handle, lever or the like.

Also, be sure to lift the machine perpendicularly and in order to avoid danger, do not draw laterally, longitudinally or at angle.

2.10.2 Self - propelling

- (1) Engage the trailer brake and chock its wheels. Fix the ramps so that the machine and trailer are completely aligned.
- ☆ The angle between the ramps and ground must be less than 15 degrees.
 - ☆ Leave a proper space between the ramps according to the width of the roller drum.

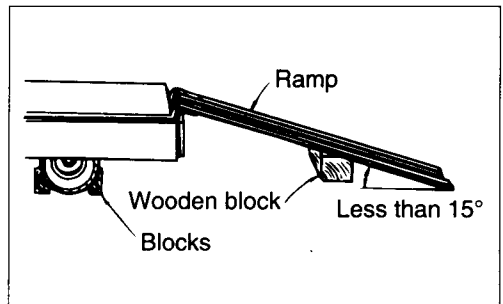

⚠ WARNING

Make certain that rumps and roll surfaces are free from water, oil and mud, etc. If they are noticeable, remove them.

- (2) Decide the correct direction of run and conduct loading or unloading at low speed.

For loading, run forward at low speed.
For unloading, run backward at low speed.

- (3) Making sure the roller has been loaded in the proper position on the truck, set the F-R lever to the neutral position(N) and shut down the engine.

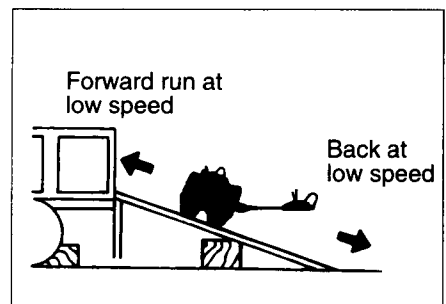

2. OPERATION

2.11 After Loading the Machine

When the machine has been located properly on the trailer, tie it down as follows:

- 1) Set the parking lock lever to the "LOCK" position.
- 2) When loading is complete, put wooden blocks at the front and rear of the rolls. Anchor the front and rear of the roller to the truck with wire ropes and suitable two hooks to prevent the machine from moving.
- 3) When unloading, check to see that the roller has slipped out of place or is floating, before removing ropes etc. which fasten the roller to the track.

2.12 Operation in Cold Weather

In cold weather, take the following measures to prevent troubles such as starting difficulty and coolant freeze-up.

2.12.1 Fuel oil and grease

Use fuel and oil with low viscosity. See "Rating" on page 48.

2.12.2 Battery

WARNING

- Batteries generate explosive gases. Do not use an open flame close to batteries.
- The battery electrolyte is corrosive. Keep the electrolyte away from your eyes and skin. If you are affected by the electrolyte, flush with large quantities of water and get medical help.

At low temperature, batteries are less efficient. The level of charge is lowered and batteries will tend to freeze. Maintain batteries full charged wherever practicable, and give attention to heat insulation at night for the next day's operation.

Check the color of the hydrometer attached to the battery top to charge or replace the battery.

Green Good
Black Discharged too much
White Checking required

2.13 After Operation

Follow the procedures below to prevent the machine from falling into an unworkable condition the following morning caused by muds and other extraneous matter on the drum, or frozen drums:

- 1) Remove muds and water from the machine. Muds can get into the seals together with water drops on the hydraulic cylinder piston rod. Damaged seals will result.
- 2) Park the machine on a hard and dry surface. If such a place is not available, cover the ground with hard plates.
- 3) Low temperature will cause a significant reduction of battery efficiency. Cover batteries or take them off from the machine and store in a warm place for the following day's operation.
- 4) To prevent freezing, drain water from the sprinkler system (See page 29).

IMPORTANT

- **Insufficient draining of water can cause troubles or damage to the system.**
- **If pressurized water is used for washing the machine, exercise caution not to allow water to penetrate into the exhaust pipe. The engine can break down.**

2.14 When the Cold Season is Over

When winter is over and the warm season has come, proceed as follows:

Change oil and fuel with those for use in warm season referring to "Rating" on page 48.

2. OPERATION

2.15 For a Long Storage Period

For leaving the machine unused for longer than one month, proceed as follows:

- 1) Store the machine in a closed area after cleaning.
- 2) Conduct oiling, greasing and changing of oil.
- 3) Grease lubricate the exposed portion of hydraulic cylinder piston rods.
- 4) Cover the battery after disconnecting the negative cable or take off the battery from the machine and store in a safe place.
- 5) Completely drain the sprinkler system.
- 6) Place the F-R lever in the neutral position (N), Vibrator switch in the OFF position, and place the parking lock lever in "Lock" position.
- 7) Chock the machine.
- 8) Remove the starter switch key.

2.16 During the Storage Period

⚠ WARNING

If necessary to operate the machine for anti-corrosive purpose in closed area, ensure good ventilation keeping windows and doors open to prevent gas poisoning.

- During storage, operate the machine at least once a month to prevent the oil films on the lubricated parts from deteriorating and to charge the batteries.

2.17 When the Battery has Discharged

⚠ WARNING

- To check and handle the batteries, keep the engine stopped with the starter switch in the OFF position.
- The batteries give off explosive gases. Do not smoke close to the batteries. Keep flames and sparks away from the batteries.
- The electrolyte is very corrosive and will harm your clothing or skin. If the electrolyte has come into contact with your clothing or skin, flush with sufficient amount of water. In case the electrolyte has gotten into your eyes, flush with water and get medical help.
- To disconnect the battery cables, start with the negative terminal (earth). When connecting, start with the positive terminal. Do not allow a metallic item to bridge between the positive terminal and machine body. This can generate sparks, causing an explosion.
- Loose battery terminals can cause sparks. An explosion will result. When connecting the terminals, make certain that they are tight.

Disconnect with negative cable first

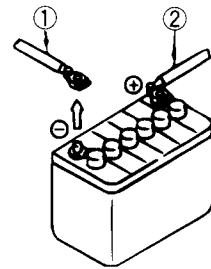

Connect with positive cable first

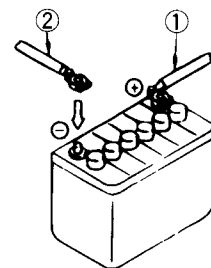

2.17.1 Connection and disconnection of booster cables

When jump-starting the engine, connect the booster cables as follows:

■ Connection of booster cables

- (1) Connect one end of the positive booster cable (A) to the positive (+) terminal of the battery on the machine.
- (2) Connect the other end of the positive booster cable to the positive (+) terminal of the booster supply.
- (3) Connect the negative booster cable (B) to the negative (-) terminal of the booster supply.
- (4) Connect the other end of the negative booster cable to a good earth of the engine block of the machine.

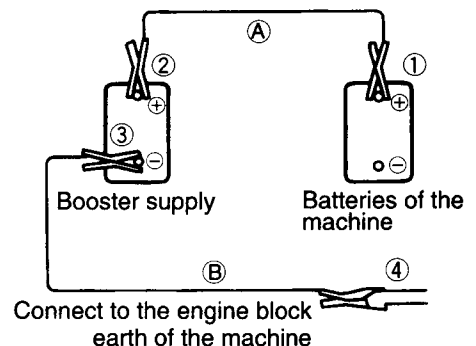

2. OPERATION

■ Disconnection of booster cables

- (1) Disconnect the negative booster cable (B) from the engine block earth.
- (2) Disconnect the negative booster cable (B) from the booster supply.
- (3) Disconnect the positive booster cable (A) from the booster supply.
- (4) Disconnect the positive booster cable (A) from the machine.

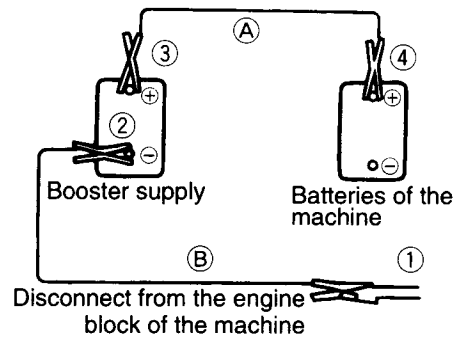

⚠ WARNING

- Do not allow the positive (+) terminal to make contact with the negative (-) terminal when connecting the booster cables.
- Wear safety goggles when jump-starting the engine.
- Do not allow the machine to make careless contact with the booster supply.
- Do not make wrong connections. Connect the negative (-) cable to the engine block earth far away from the battery, as sparks may occur when connecting.

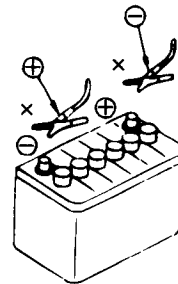

⚠ CAUTION

- Use booster cables and end clips of proper size suited to the battery capacity.
- Use the batteries of the equal capacity for the machine and booster supply.
- Check booster cables and end clips for signs of damage and corrosion.
- Connect the clips positively.

2.18 Prevention of Engine Trouble due to Water Entering Engine Cylinder (Measures against Water Hammer):

(Applicable to KUBOTA and YANMAR engine mounted models)

2.18.1 Preventive Measures against Water Entering

- In order to prevent water from entering, take necessary measures e.g. by covering the exhaust with a cap or the like against rain fall or accumulated snow during long term outdoor storage, when leaving the machine unattended at job site or through washing the machine with high pressure water. Particular care should be taken at the time of heavy rain or snowfall.

2.18.2 Inspection Prior to and Rules for Starting-Up the Engine:

When water is anticipated to have entered the engine after rain or snowfall, carried out the following procedures at the time of starting-up the engine because engine trouble due to water hammer can be incurred otherwise:

Prior to starting-up the engine:

- As it is possible that water has entered engine oil, be sure to check the condition of engine oil and replace it as necessary (See 3. Inspection and Maintenance Section for engine oil replacement procedure).

At the time of starting-up the engine:

- With throttle lever placed at Off position and decompression lever pulled, perform cranking operation a few times by means of crank handle or starter motor (See Engine Instruction Manual for cranking operation).
Residual water will be removed through exhaust valve, causing any possibility for trouble to be reduced.
- After making sure that water has been removed, start-up the engine with normal procedure.
- If there is any possibility of water having entered, try not to start-up the engine immediately with normal procedure.

3. PERIODICAL MAINTENANCE

3. PERIODICAL MAINTENANCE

3.1 Precautions

Whether or not the inspection service and lubrication are performed at the correct regular intervals exerts significant influence on the occurrence of trouble and service life of the machine. In this manual, typical intervals for inspection and service are given. However, flexibility should be introduced as to interval or type of services to enable your machine to always operate in the best condition.

General precautions:

- 1) Always use Sakai genuine parts for replacement.
- 2) Use lubricants recommended by Sakai. Avoid mixing different brand lubricants.
- 3) For hydraulic oil replenishment, changing, level checking, filter cleaning or replacement, oiling and greasing, use extreme care to prevent dust from entering.
- 4) For checking oil level or changing oil, park the machine on a level and hard surface.
- 5) Change oil while its temperature remains high after operation.
- 6) For a long-term storage, fill the fuel tank, lubricate necessary points and run the machine for more than 20 minutes once a month.
- 7) In freezing weather, add antifreeze to the coolant according to the ambient temperature.
- 8) For the hydraulic pump and motor, have them serviced at authorized service shops.
- 9) Turn the starter switch OFF when performing services such as repairing broken wires, short circuits and tightening loose terminals.

Periodical Replacement of Essential Maintenance Parts

In order secure safety for work and travel, conduct inspection and services.

Further, for enhanced safety, following parts and components should be replaced periodically.

These parts are prone to material deterioration due to aging or physical change due to friction, while it is difficult to determine their useful limit by regular inspection, which makes it necessary to replace with new ones after certain period of service to maintain their perfect function.

If any abnormality is detected such as crack, deformation or oil leakage, go ahead and replace them even if it is within scheduled replacement time.

3. PERIODICAL MAINTENANCE

System or Mechanism	Part name	Periodical replacement maintenance parts	Replacement period	Remarks
1. Brake system	Master cylinder	Seals (rubber parts)	2 years	Adopted machines only
	Wheel cylinder	Seals (rubber parts)	2 years	"
	Brake piping parts	Brake hose	2 years	
		Air hose	2 years	Adopted machines only
Operating parts	Cable	4 years	"	
2. Steering system	Orbitrol	Seals (rubber parts)	2 years	
	Hydraulic piping parts	Hydraulic hose	2 years	
	Steering cylinder	Seals (rubber parts)	2 years	
	Hydraulic pump	Seals (rubber parts)	4 years	
3. Power transmission system (inclusive of axle)	Axle	Seals (rubber parts)	4 years	Adopted machines only
	Travel pump	Seals (rubber parts)	4 years	"
	Travel motor	Seals (rubber parts)	4 years	"
	Hydraulic piping parts	Hydraulic hose	4 years	"
	Isolation rubber	Isolation rubber itself	4 years	"
4. Fuel system	Piping parts	Fuel hose	4 years	
5. Engine related	Engine mounting parts	Isolation rubber	4 years	
	Seals (rubber parts)	Packing and others	4 years	
	Drive parts	V-belt	2 years	
6. Cooling system	Piping parts	Radiator hose	2 years	
7. Control related parts	Cable	Cable	4 years	Adopted machines only

⚠ CAUTION

- With a new machine, change engine oil (see page 42), adjust the fan belts (page 44) and the drive belts (page 45) after 20 operating hours, (50 hours for KUBOTA engine and YANMAR engine) operating for the first time only.
- Check the electric wiring at a regular interval not exceeding one month:
 - 1) Damage to the wire harness and loose clamps
 - 2) Loose sockets
 - 3) Function of electrical systems

3. PERIODICAL MAINTENANCE

3.2 Walk-Around Checking

(1) Every 10 hours (daily)

Engine crank case

With engine positioned horizontally, Check oil level.
Replenish if the level is not in between the marks on gauge.

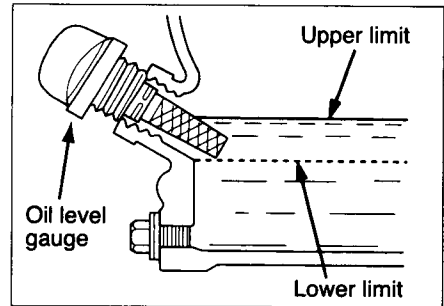

HONDA engine mounted models

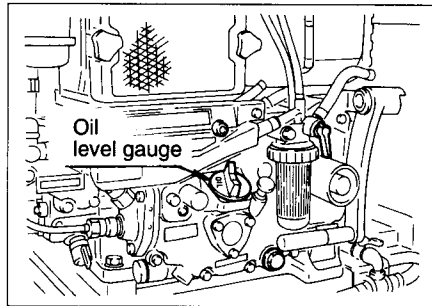

KUBOTA engine mounted models

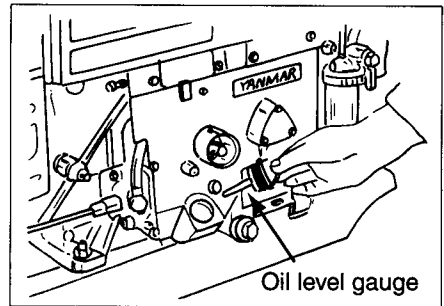

YANMAR engine mounted models

Radiator (Applicable to KUBOTA and YANMAR engine mounted models)

Make sure that coolant is up to the neck of filler port.

In not, replenish.

⚠ WARNING

Try not to remove radiator cap while coolant is hot.

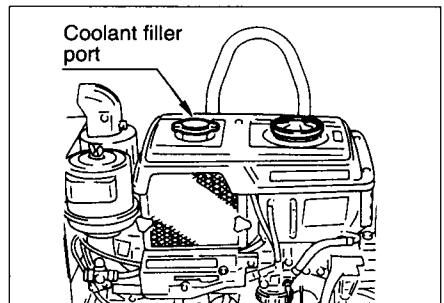

3. PERIODICAL MAINTENANCE

Fuel tank

Check fuel level with fuel gauge.

⚠ CAUTION

For refueling, park the machine on a level and solid surface.

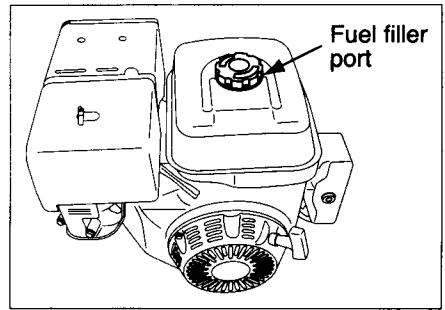

HONDA engine mounted models

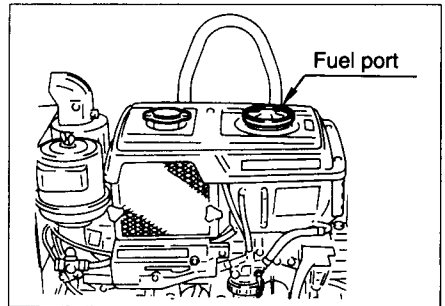

KUBOTA and YANMAR engine mounted models

(2) Every 50 hours

Hydraulic tank

- ① Check oil level with level gauge.
- ② Level is proper when it is seen in the middle of gauge.
- ③ If insufficient, replenish through filler port.

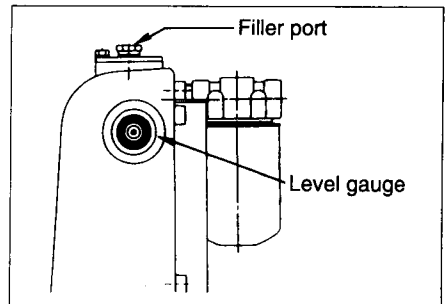

Battery

- ① Check the color of the hydrometer attached to the battery top to charge or replace the battery.

Green ... Good

Black ... Discharged too much

White ... Checking required

- ② Retighten any loose terminal. Apply grease or vaseline to the terminals to retard rusting.

3. PERIODICAL MAINTENANCE

(3) Every 100 hours

Engine crank case

- ① Replace engine oil.
- ② Remove drain plug to allow oil to be drained while oil temperature remains warm after operation.
- ③ Tighten drain plug and fill oil.

⚠ WARNING

When draining a hot oil, use care not to get burned.

IMPORTANT

For a new machine, change oil at 20 operating hours (50 hours for KUBOTA engine and YANMAR engine) for the initial time only.

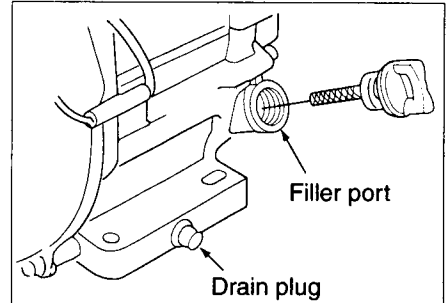

HONDA engine mounted models

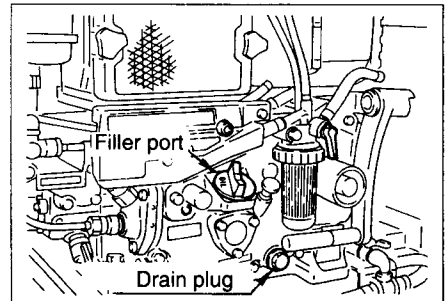

KUBOTA engine mounted models

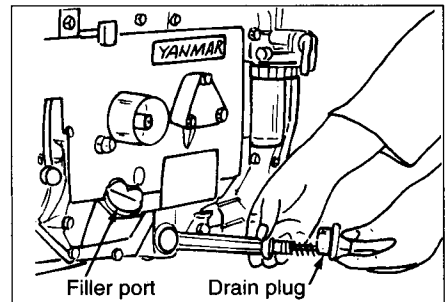

YANMAR engine mounted models

3. PERIODICAL MAINTENANCE

Fuel filter

- ① With sediment cup removed, remove any dust or water accumulated at the bottom.
- ② Rinse sediment cup and element in fresh Gas oil.

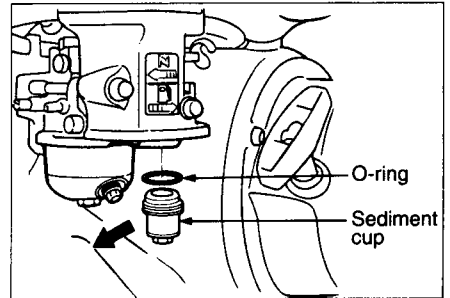

HONDA engine mounted models

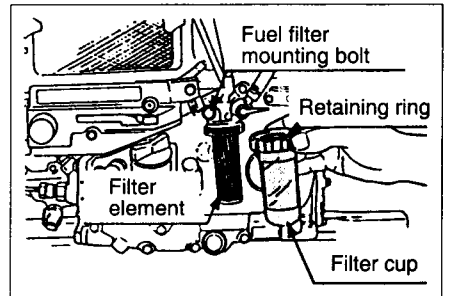

KUBOTA and YANMAR engine mounted models

Air cleaner

- ① After removing dust from cup, wipe the interior to clean.
- ② Clean the element by tapping it lightly or with compressed air blown from inside to remove dust.

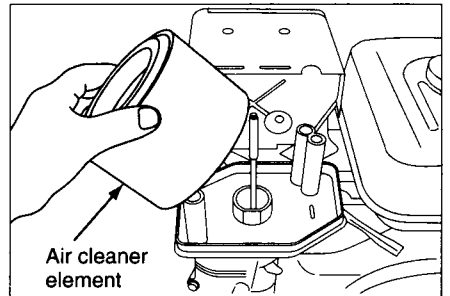

HONDA engine mounted models

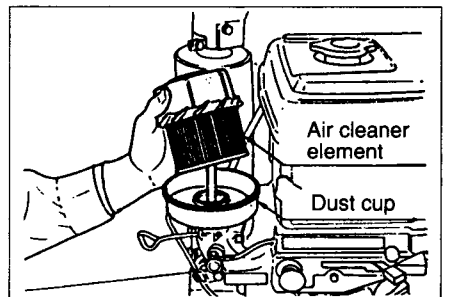

KUBOTA and YANMAR engine mounted models

▲ WARNING

Exercise caution not to get a speck of dust in your eye.

IMPORTANT

- Where operating environment is dusty, cleaning should take place in more frequent interval.
- Any element which has been damaged or has hole in it should be replaced with new one.
- Air cleaner should be renewed every year or after six cleanings.

3. PERIODICAL MAINTENANCE

Spark plug (Applicable to HONDA engine mounted models)

Remove the spark plug to clean off carbon deposit on the plug. Adjust electrode gap to between 0.7mm and 0.8mm.

Spark plugs to be employed:

BPR6ES (NGK), W20EPR-U (DENSO)

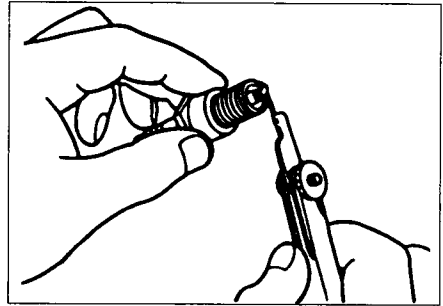

Fan belt (Applicable to KUBOTA and YANMAR engine mounted models)

KUBOTA engine mounted models

Checking the belt tension:

Belt tension is proper if slack is 5 to 10mm when depressed between the pulleys with thumb.

Adjustment:

With nut loosened, turn tension bolt clockwise to increase tension before tightening the bolt securely.

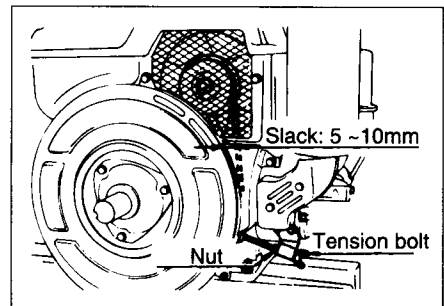

⚠ WARNING

Excessive belt tension will cause engine trouble. Exercise care.

YANMAR engine mounted models

With tension pulley lever tightening bolt ① loosened, press down tension pulley lever ② and obtain appropriate tension before tightening the tension pulley lever tightening bolt ① again.

Belt tension is proper if slack is 15 to 20mm when depressed midway with finger.

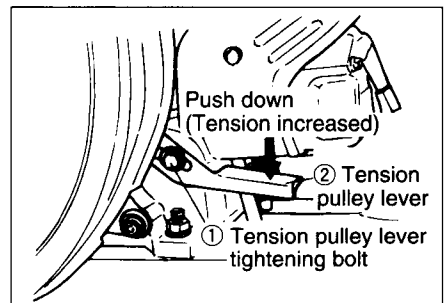

⚠ WARNING

Excessive belt tension will cause engine trouble. Exercise care.

IMPORTANT

With a new roller, V belt tension should be adjusted after 50 hours of operation as an exception for the first time only.

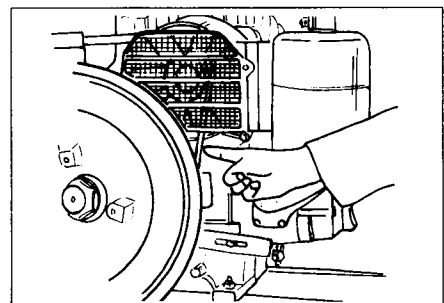

3. PERIODICAL MAINTENANCE

Drive belt

Checking the tension:

Tension of this belt is proper if it slacks 2 to 3mm when depressed at its midway with a force of about 3kg.

Adjustment:

With pump bracket mounting bolts (A) (4 locations) loosened, loosen the nut of adjust bolt (B) and adjust tension using the bolt, before tightening those loosened bolt and nut again.

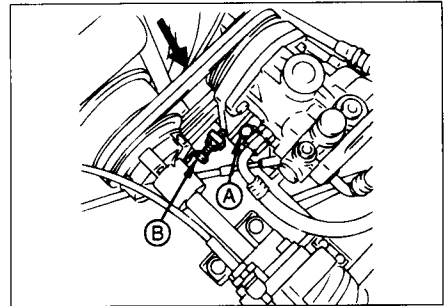

IMPORTANT

With a new roller, V belt tension should be adjusted after 20 operating hours (50 hours for KUBOTA engine and YANMAR) engine as an exception for the first time only.

(4) Every 200 hours

Hydraulic oil filter

Replace filter cartridge.

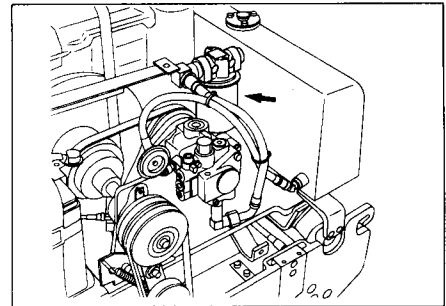

Gear reducer

Apply grease to gear reducer for both front and rear roll.

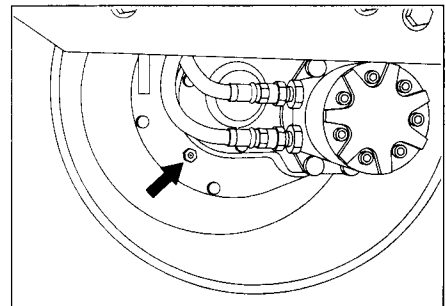

3. PERIODICAL MAINTENANCE

(5) Every 500 hours

Hydraulic oil tank

- ① Remove drain plug of hydraulic oil tank while oil remains warm and drain oil.
- ② After cleaning the tank interior, fill the tank with new oil to specified level.
- ③ Start engine and run it for 2 to 5 minutes at idling speed. After making sure that bubbles have disappeared from oil, stop engine and check the oil level again.

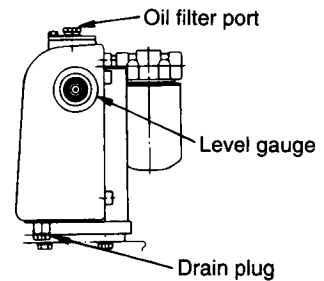

⚠ WARNING

When draining a hot oil, use care not to get burned.

Radiator (Applicable to KUBOTA and YANMAR engine mounted models)

Clean the fins to eliminate clogging.

Idle pulley movable shaft for vibration

Apply grease to idle pulley movable shaft.

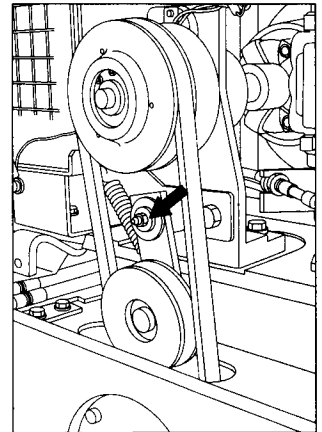

Control handle

Apply grease to control handle and lock pin.

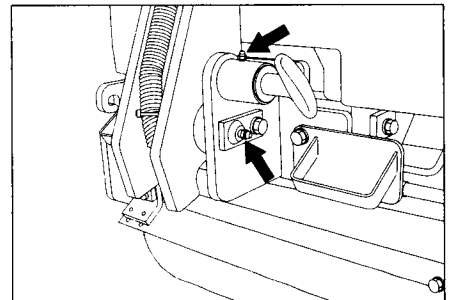

3. PERIODICAL MAINTENANCE

Safety system knob

Apply grease to pipe.

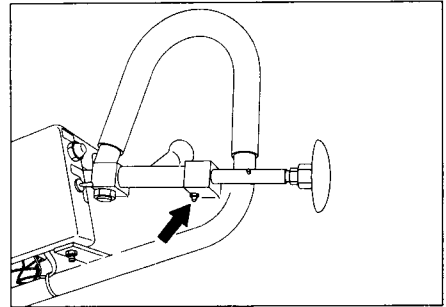

Swing bearing

Apply grease to 2 locations.

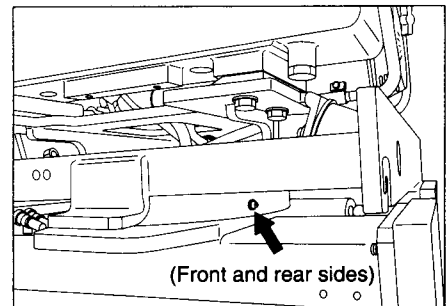

Steering cylinder

Apply grease to the cylinder head pin and piston rod pin.

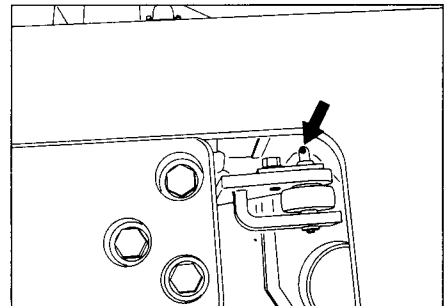
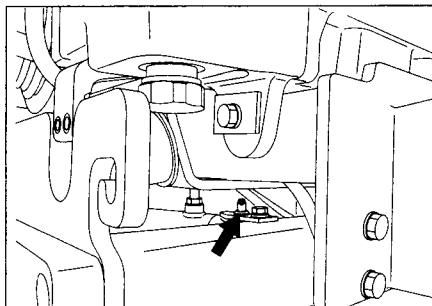

3. PERIODICAL MAINTENANCE

3.3 Feeding Water and Lubricants

3.3.1. General rules

- 1) Never feed water or lubricant with the strainer removed.
- 2) Use recommended lubricant and hydraulic fluid.
- 3) Do not use lubricants and hydraulic fluid of different brands.
- 4) When replacing oil, drain it completely and clean the container with flushing oil before filling new oil.

3.3.2. Capacity

Replenishing point	Type	Capacity in liters (gal)		
		HONDA engine	KUBOTA engine	YANMAR engine
Fuel tank	Gasoline	6.5 (1.7)	—	—
	Diesel fuel	—	4.7 (1.2)	5.6 (1.5)
Engine oil pan	Engine oil	1.1 (0.3)	1.3 (0.3)	1.2 (0.3)
Hydraulic oil tank	Hydraulic oil	16 (4.3)	16 (4.3)	16 (4.3)
Radiator	Coolant	—	1.2 (0.3)	1.2 (0.3)
Sprinkler tank	Water	30 (8.0)	30 (8.0)	30 (8.0)

3.3.3. Rating

HONDA

Lubricant	Service classification	Ambient temp. and applicable viscosity rating			Applicable standards
		-30 ~ 0°C Cold	-20 ~ 40°C Moderate	10 ~ 40°C Tropical	
Engine oil	API grade SF or SG	SAE 5W-30	SAE 10W-30	SAE 30	MIL-L-2104C
Hydraulic oil	Wear resistant	ISO-VG32 over VI 140	ISO-VG32 over VI 140	ISO-VG68 over VI 110	ISO-3448
Grease	Lithium type extreme pressure NLGI-2				
Fuel	Gas oil JIS · K2202-2				

VI: Viscosity Index

KUBOTA, YANMAR

Lubricant	Service classification	Ambient temp. and applicable viscosity rating			Applicable standards
		-30 ~ 0°C Cold	-20 ~ 40°C Moderate	10 ~ 40°C Tropical	
Engine oil	API grade SF or SG	SAE 5W-30	SAE 10W-30	SAE 40	MIL-L-2104C
Hydraulic oil	Wear resistant	ISO-VG32 over VI 140	ISO-VG32 over VI 140	ISO-VG68 over VI 110	ISO-3448
Grease	Lithium type extreme pressure NLGI-2				
Fuel	Gas oil JIS · K2202-2 ASTM · D975-2D				

VI: Viscosity Index

3. PERIODICAL MAINTENANCE

3.3.4. Recommended lubrications

Lubricant Oil company	Engine oil API – CD	Gear oil API GL 4	Hydraulic oil VG 46	Grease (NLGI – II)
CALTEX	RPM DELO 300 oil	Universal Thuban 90	Rando Oil HD 46	Martifack EP 2
BP	BP Vanellus C3–30	BP Grease oil EP 90	BP Energol HLP 46	EP Energrease LS – EP 2
ESSO	Esso Lube D3–30	Esso Gear Oil GP 90	Nuto H 46	Beacon EP 2
MOBIL	Mobil Delvac 1330	Mobil Pegasus Gear Oil 90	Nuto Oil 25	Beacon EP 25
SHELL	Shell Rotella CT Oil 30	Shell Spirax 90 EP	Shell Tellus Oil 46	Shell Alvania EP Grease 2
CASTROL	Castrol CRD 30	Castrol Hypoy 90	Hyspin AWS 46	Spherrol ELP 2

- CAUTION:** (1) Fill the fluid reservoirs with the filters installed.
 (2) Use recommended fuels and lubricants only.

3. PERIODICAL MAINTENANCE

3.4 Electric Wiring Diagram

= HONDA engine mounted models =

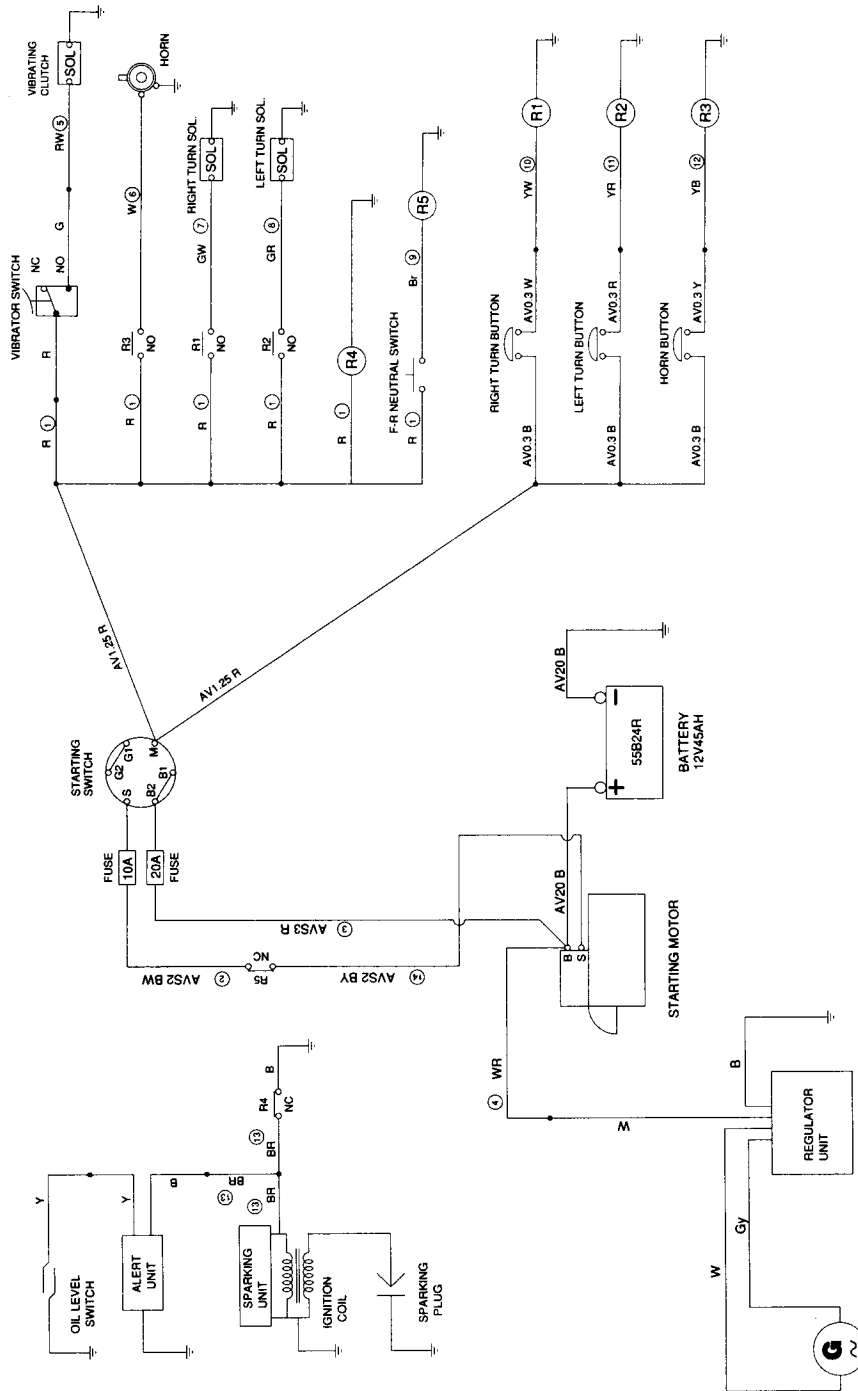

CAUTION: Size of wires not indicated by letters are AV 0.85.

Color of wire

B	Black	BR	Brown	GR	Green	LR	Blue	P	Pink	RB	Black stripe	WR	White stripe	YR	Yellow/Red stripe	LB	Blue/Black stripe
BR	Black/Red stripe	BW	Brown/White stripe	GW	Green/White stripe	LW	Blue/White stripe	R	Red	RB	Black stripe	Y	Yellow	YW	Yellow/White stripe	WG	White/Green stripe
BW	Black/White stripe	G	Green	GY	Green/Yellow stripe	LY	Blue/Yellow stripe	RB	Red/Black stripe	W	White	YB	Yellow/Black stripe	BY	Brown/Yellow stripe		
BY	Black/Yellow stripe	GB	Green/Black stripe	Gr	Gray	Lg	Light green	RG	Red/Green stripe	WB	White/Black stripe	YG	Yellow/Green stripe	Sb	Blue		
Br	Brown	GL	Green/Blue stripe	L	Blue	O	Orange	RL	Red/Blue stripe	WL	White/Blue stripe	YL	Yellow/Blue stripe	BG	Black/Green stripe		

3. PERIODICAL MAINTENANCE

= YANMAR engine mounted models =

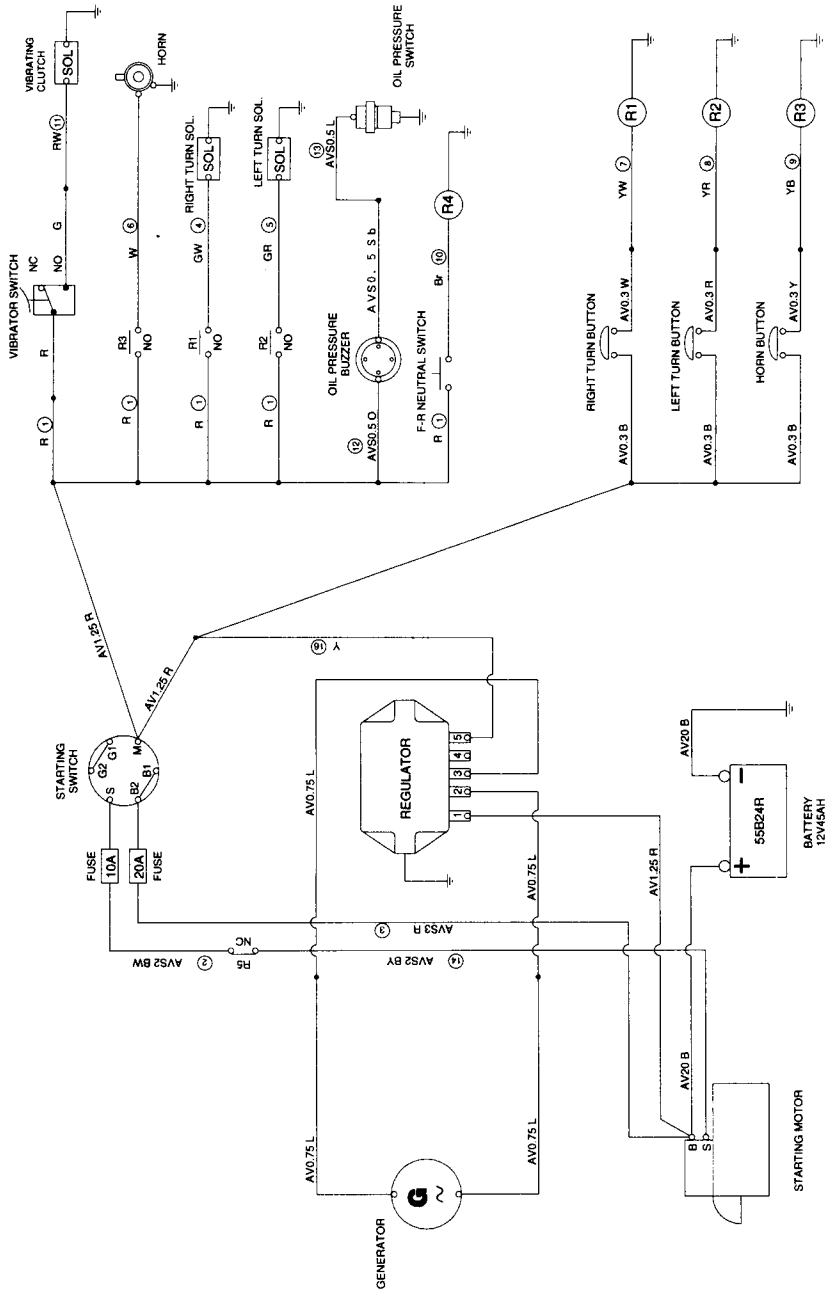

CAUTION: Size of wires not indicated by letters are AV 0.85.

Color of wire

B	Black	BR	Brown/Red stripe	GR	Green/Red stripe	LR	Blue/Red stripe	P	Pink	RW	Red/White stripe	WR	White/Red stripe	YR	Yellow/Red stripe	LB	Blue/Black stripe
BR	Black/Red stripe	BW	Brown/White stripe	GW	Green/White stripe	LW	Blue/White stripe	R	Red	RY	Red/Yellow stripe	Y	Yellow	YW	Yellow/White stripe	WG	White/Green stripe
BW	Black/White stripe	G	Green	GY	Green/Yellow stripe	LY	Blue/Yellow stripe	RB	Red/Black stripe	W	White	YB	Yellow/Black stripe	BY	Brown/Yellow stripe		
BY	Black/Yellow stripe	GB	Green/Black stripe	Gr	Gray	Lg	Light green	RG	Red/Green stripe	WB	White/Black stripe	YG	Yellow/Green stripe	Sb	Blue		
Br	Brown	GL	Green/Blue stripe	L	Blue	O	Orange	RL	Red/Blue stripe	WL	White/Blue stripe	YL	Yellow/Blue stripe	BG	Black/Green stripe		

4. SPECIFICATIONS

= HONDA engine mounted models =

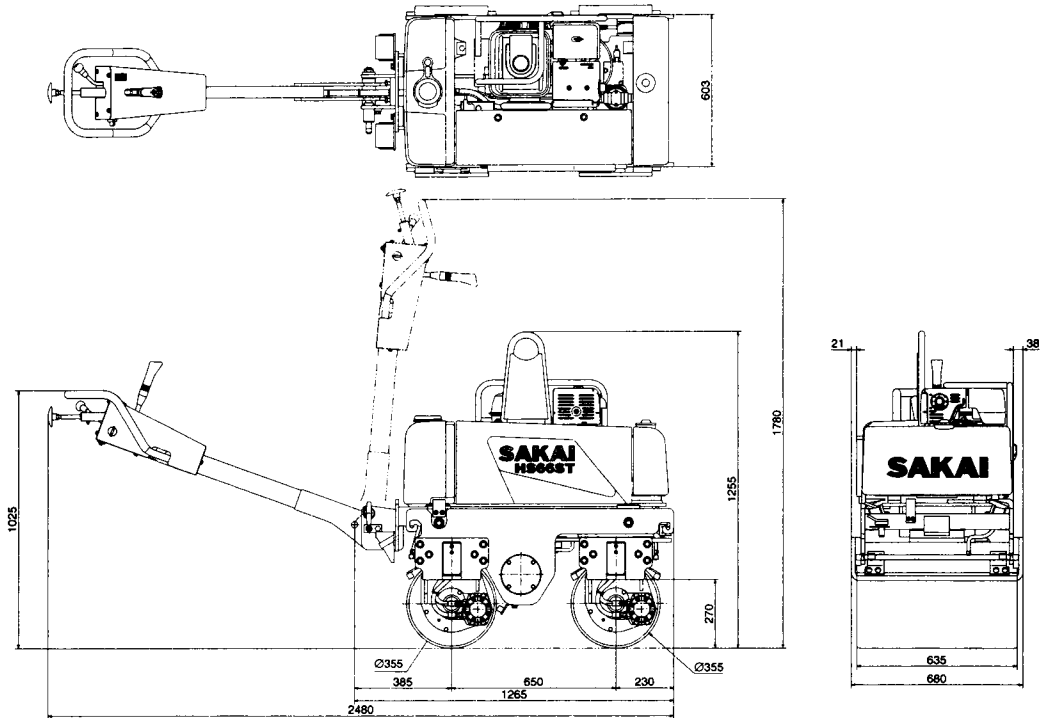

Model	HS66ST
Weight:	
Gross Weight	680 kg (1,499 lbs)
Weight	650 kg (1,433 lbs)
Dimensions:	
Overall length	2,480 mm (98 ")
Overall width	680 mm (26.8 ")
Overall height	1,255 mm (49 ")
Roll dia. x width	355 mm x 635 mm (14" X 25")
Wheel base	650 mm (25.6 ")
Performance:	
Compaction width	635 mm (25.6 ")
Vibrator:	
Vibratory force	11.8 kN {1,200 kgf} (2,646lbs)
Frequency	55 Hz {3,300 vpm}

Model	HS66ST
Performance:	
Speed	0~3.5km/h(0~2.1mile/h)
Gradability	25 degrees
Engine:	
Model	HONDA GX390K1 (Gasoline engine)
Displacement	0.389L {389 cc} (23.7 cu.in)
Rated output	7.4kW {10.0 PS} (9.9HP)
Max. torque	26.5 N·m {2.7 kgf·m} / 2,500 min ⁻¹ (19.5ft·lb/2,500rpm)
Battery	12V 45Ah

NOTE: Gradability is the calculated value. It may vary with ground surface conditions.

4. SPECIFICATIONS

= KUBOTA engine mounted models =

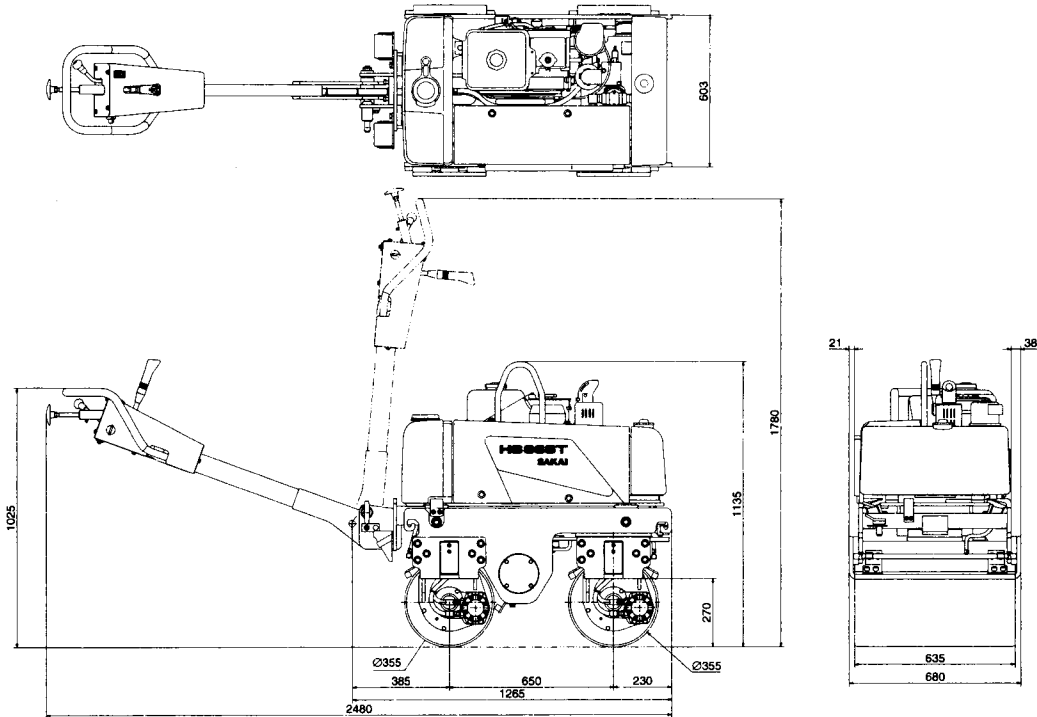

Model	HS66ST
Weight:	
Gross Weight	690 kg (1,521 lbs)
Weight	660 kg (1,455 lbs)
Dimensions:	
Overall length	2,480 mm (98 ")
Overall width	680 mm (26.8 ")
Overall height	1,135 mm (45 ")
Roll dia. x width	355 mm x 635 mm (14" X 25")
Wheel base	650 mm (25.6 ")
Performance:	
Compaction width	635 mm (25 ")
Vibrator:	
Vibratory force	11.8 kN {1,200 kgf} (2,646lbs)
Frequency	55 Hz {3,300 vpm}

Model	HS66T
Performance:	
Speed	0~3.5km/h(0~2.1mile/h)
Gradability	25 degrees
Engine:	
Model	KUBOTA E75-NB3 (Diesel engine)
Displacement	0.325L {325 cc} (19.8 cu.in)
Rated output	4.0kW{5.5 PS}(5.4HP)
Max. torque	18.1 N·m{1.9 kgf·m}/2,000 min ⁻¹ (13.4 ft·lb/2,000rpm)
Battery	12V 45Ah

NOTE: Gradability is the calculated value. It may vary with ground surface conditions.

4. SPECIFICATIONS

= YANMAR engine mounted models =

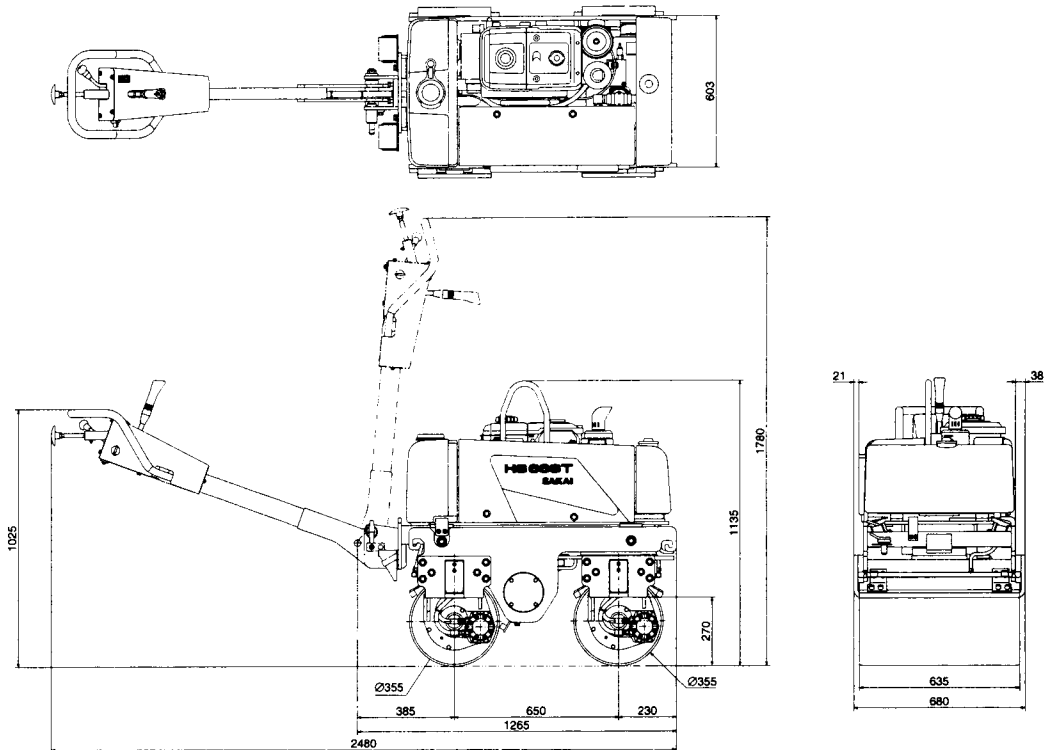

Model	HS66ST	Model	HS66ST
Weight:		Performance:	
Gross Weight	690 kg (1,521 lbs)	Speed	0~3.5km/h (0~2.1mile/h)
	660 kg (1,455 lbs)	Gradability	25 degrees
Dimensions:		Engine:	
Overall length	2,480 mm (98 ")	Model	YANMAR NFAD6-ESA (Diesel engine)
Overall width	680 mm (26.8 ")	Displacement	0.309L {309 cc} (18.9 cu.in)
Overall height	1,135 mm (45 ")	Rated output	3.9kW {5.3 PS} (5.2HP)
Roll dia. x width	355 mm x 635 mm (14" X 25")	Max. torque	19.6 N·m {2.0 kgf·m} / 2,000 min ⁻¹ (14.5ft·lb / 2,000rpm)
Wheel base	650 mm (25.6 ")	Battery	12V 45Ah
Performance:			
Compaction width	635 mm (25 ")		
Vibrator:			
Vibratory force	11.8 kN {1,200 kgf} (2,646lbs)		
Frequency	55 Hz {3,300 vpm}		

NOTE: Gradability is the calculated value. It may vary with ground surface conditions.

SAKAI HEAVY INDUSTRIES, LTD.

Head Office: 1-4-8, Shiba Daimon, Minato-ku,
Tokyo, Japan

Telephone : Tokyo (03) 3431-9971

Facsimile : Tokyo (03) 3436-6212

SAKAI HEAVY INDUSTRIES, LTD.