

THE
BARRETO

MODEL 825TKL SKID LOADER

OPERATOR'S MANUAL

MACHINE INTENDED USE

This Track Loader is designed to attach to industry-standard tools and implements for light and medium duty construction and landscaping work.

TABLE OF CONTENTS

| | |
|--|----|
| UNIT OVERVIEW SPECS AND DIMENSIONS | 2 |
| HYDRAULIC SCHEMATIC | 5 |
| SAFETY MESSAGES | 6 |
| BATTERY & ELECTRIC STARTER SAFETY INSTRUCTIONS | 9 |
| MACHINE OPERATING INSTRUCTIONS | 10 |
| CONTROLS | 10 |
| ENGINE START UP PROCEDURE | 11 |
| SHUT DOWN PROCEDURE | 11 |
| DRIVING PROCEDURE | 12 |
| ATTACHMENTS | 13 |
| DISPLAY PANEL FEATURES | 15 |
| TOOL OPERATION | 17 |
| JUMP STARTING ENGINE WITH ELECTRIC STARTER | 19 |
| EMERGENCY TOWING | 21 |
| ROAD TRANSPORT | 23 |
| OPERATOR PREPARATION | 24 |
| DETERMINE LOCATION OF UNDERGROUND UTILITIES | 25 |
| WORK SITE ASSESSMENT | 26 |
| CONTACT WITH UNDERGROUND UTILITIES | 27 |

UNIT OVERVIEW: SPECS & DIMENSIONS

| | U.S. | METRIC |
|---|---------------|---------------|
| DIMENSIONS (STD) | | |
| Operating height, max, std. bucket | 105.75 in. | 2.68 m |
| Overall length of machine, std. bucket | 106.5 in | 2.7 m |
| Overall length of loader, no attachment | 80.12 in | 2.04 m |
| Machine weight (no attachment, fluids full) | 2950 lb | 1338 kg |
| Hinge pin height, max | 80 in | 2.03 m |
| Track length | 39.12" | 1 m |
| Track Width | | |
| Max: 230 mm tracks | 36.6 in | .93 m |
| Min: 180 mm tracks | 35.5 in | .9 m |
| 825TKL ground clearance | 7.25 in | 184 mm |
| 825TKL tipping capacity | 2325 lb | 1054.6 kg |
| 825TKL rated operating capacity | | |
| 35% of tipping capacity | 800 lb | 362.88 kg |
| Angle of departure | 28° | 28° |
| POWER | | |
| Engine | Kubota D11105 | Kubota D11105 |
| Fuel | Diesel | Diesel |
| Net power rating | 25 hp | 25 hp |
| Emission compliance | EPA Tier 4 | EPA Tier 4 |
| Number of cylinders | 3 | 3 |
| Displacement | 68.5 ci | 1123 cc |
| Bore | 3.07 in | 78 mm |
| Stroke | 3.09 in | 78.4 mm |
| Rated Speed | 3000 rpm | 3000 rpm |

| | U.S. | METRIC |
|---------------------------------------|----------|----------|
| OPERATION | | |
| Ground drive speed | | |
| Forward | 5.1 mph | 7.2 kmh |
| Reverse | 3.6 mph | 5.8 kmh |
| Ground pressure* | | |
| 230 mm tracks | 4.6 psi | .32 bar |
| 180 mm tracks | 5.9 psi | .41 bar |
| HYDRAULIC SYSTEM | | |
| Auxiliary circuit | | |
| Tandem Gear Pump | | |
| Flow rate (Pump #1) | 13 gpm | 49 lpm |
| Flow Rate (Pump #2) | 6.5 gpm | 24.6 lpm |
| Pressure relief (Pump #1) | 3000 psi | 207 bar |
| Pressure relief (Pump #2) | 2250 psi | 155 bar |
| Tandem Hydrostatic ground drive pumps | | |
| Flow rate | 14 gpm | 54 lpm |
| Pressure relief | 3045 psi | 210 bar |
| FLUID CAPACITIES | | |
| Fuel | 9 gal | 34 ltr |
| Engine oil with filter | 5 qt | 4.7 ltr |
| Hydraulic reservoir | 10.8 gal | 40.9 ltr |

* Includes machine weight, 175lb. bucket (80kg) and 165lb. operator (75kg).

Specifications are subject to change without notice. If exact measurements are required, equipment should be weighed and measured. Due to selected options delivered equipment may not necessarily match that shown.

825TKL ORIENTATION

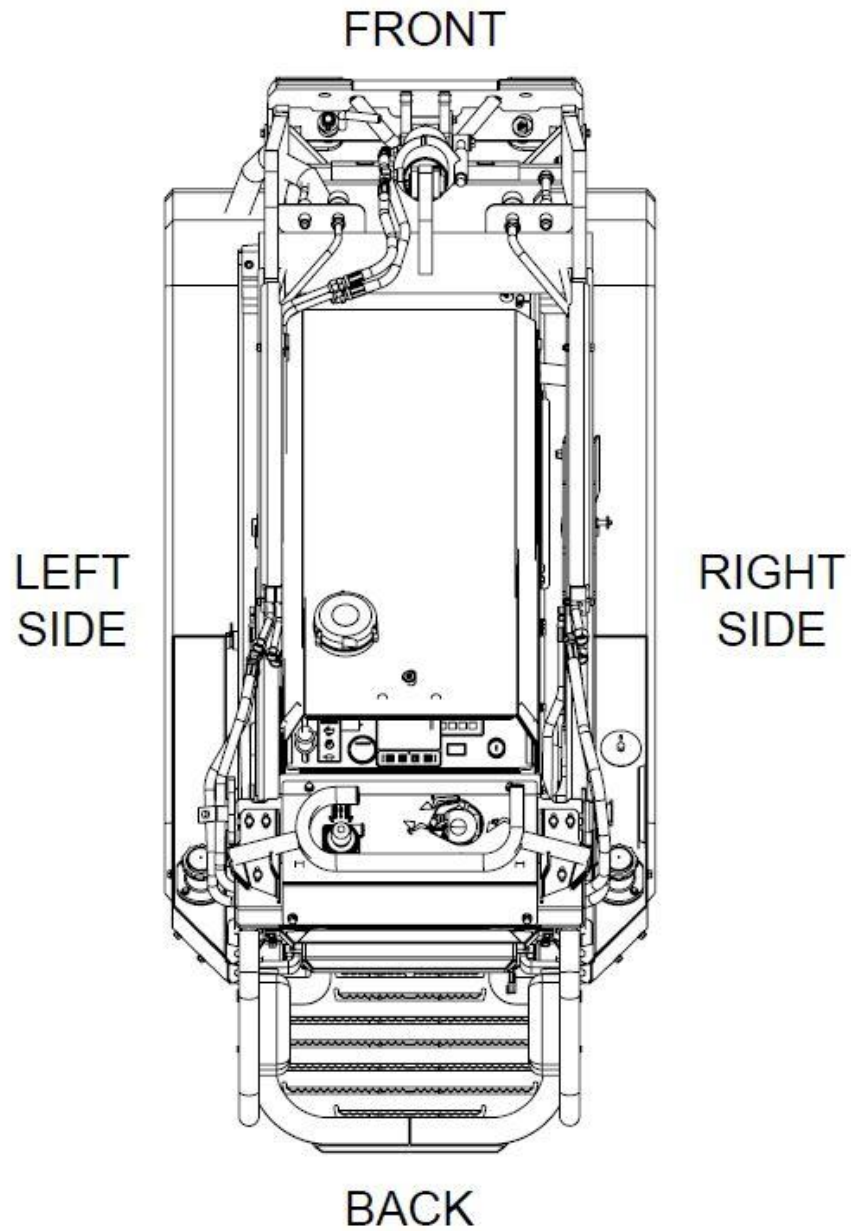

KEY COMPONENTS

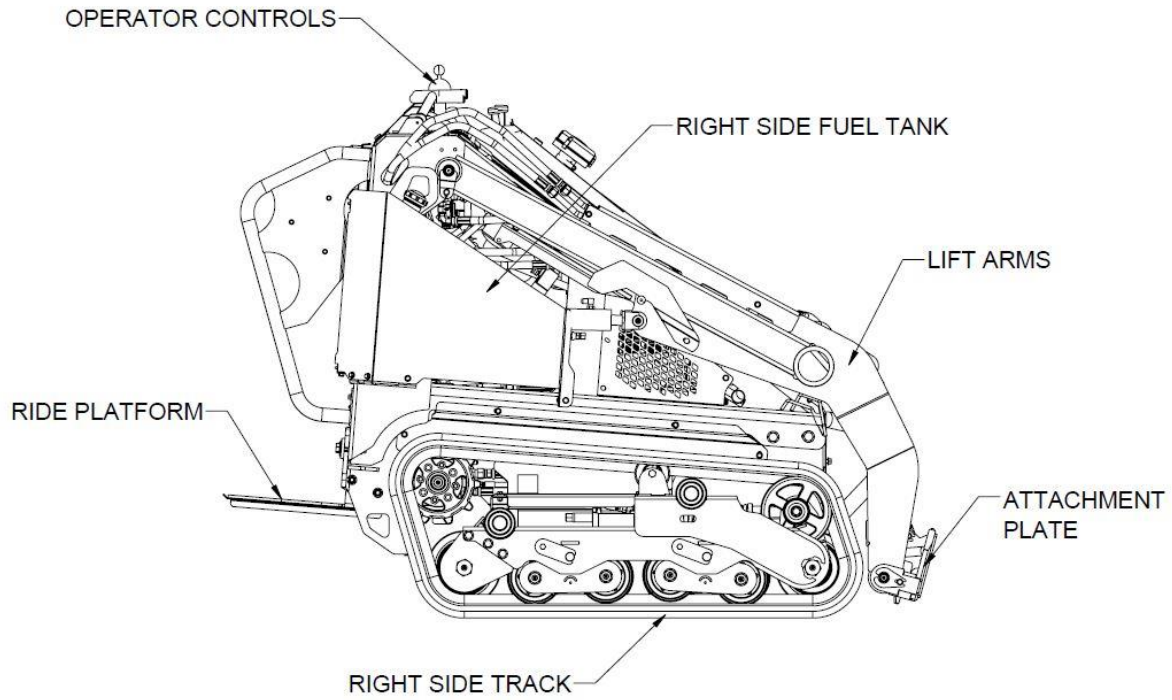

GREASE POINTS

GREASE POINTS, EVERY 10 HOURS OPERATION

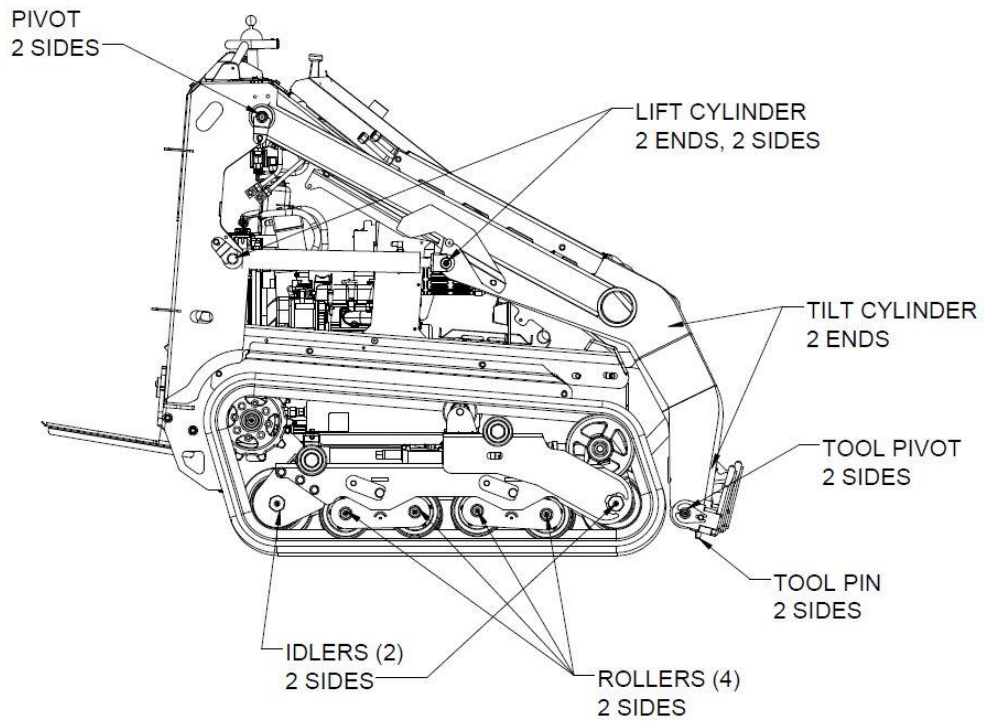

HYDRAULIC SCHEMATIC

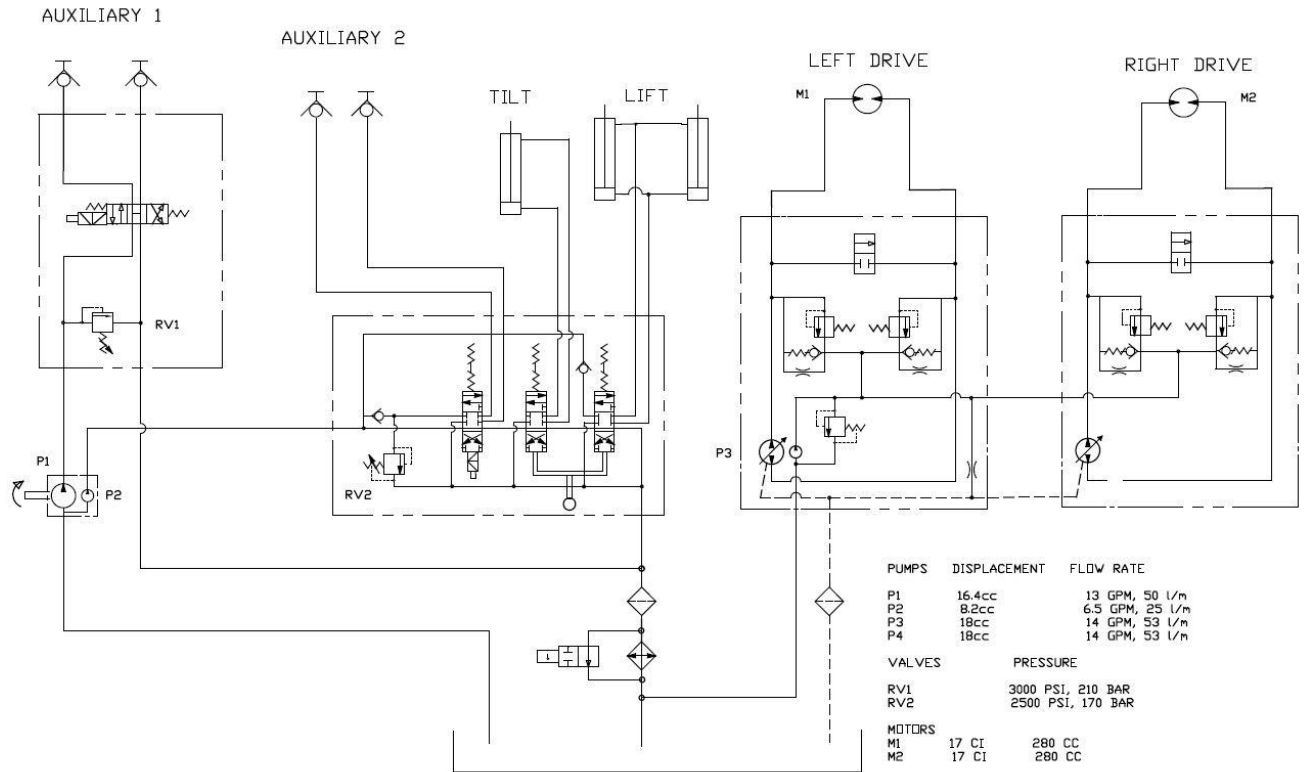

SAFETY MESSAGES

General safety messages are listed in this Safety Messages section. Specific safety messages appear as appropriate in this manual where a potential hazard may occur if procedures or instructions are not followed correctly and completely.

SAFETY SYMBOL



This is the international safety alert symbol. This symbol is used in combination with a signal word and written message to warn you of a potential for bodily injury or death.

A signal word "DANGER", "WARNING", or "CAUTION" is used with the safety alert symbol.



DANGER: Imminent hazards, that if not avoided, will result in serious personal injury or death.



WARNING: Potential hazards or unsafe practices, that if not avoided, could result in serious personal injury or death:



CAUTION: Potential hazards or unsafe practices, that if not avoided, could result in minor personal injury, product damage, or property damage.

Safety decals with a signal word "DANGER", "WARNING", or "CAUTION" are affixed to the 825TKL near specific hazards.

This machine is intended for the operator to stand on. If at any time it becomes unsafe, the operator must step off immediately.

Read this manual and study ALL decals on the machine before operating the trencher.



SAFETY INSTRUCTIONS OVERVIEW

READ SAFETY AND OPERATING INSTRUCTIONS BEFORE OPERATING!

USE COMMON SENSE AND PLENTY OF IT!

Call before you dig. If you do not call, you may cause an accident; suffer injuries or death; cause interruption of services; damage the environment; and/or incur project delays. Expect to be held liable for any damages caused, if you fail to call.



DANGER: Buried electric cables or gas lines can cause serious injury or death if struck with trenching attachments. Always determine location of utilities before trenching.



WARNING: Fiber optic cables convey laser light that can injure your eyesight.

STAY CLEAR of moving parts on the machine.



DANGER: Track Loader attachments and other moving parts can cut off arms, legs, or fingers. Contact with attachments while in operation will cause serious injury or even death.



Wear safety goggles and a hard hat while operating or observing!

Wear adequate hearing protection while operating or observing.



WARNING: Exposure to loud noise is cumulative and may permanently damage your hearing.

Wear safety boots and gloves. Wear close-fitting clothing. Contain long hair. Do not wear jewelry. Wear reflective clothing if working near traffic.



Only operate outdoors and avoid breathing engine exhaust and fumes.



WARNING: Engine exhaust contains carbon monoxide gas that is toxic. Breathing it can cause unconsciousness and death.

Adequate lighting is required, daylight or artificial, for safe operation of the trencher.

Allow adequate side and overhead clearances between the 825TKL and buildings, fences, and trees.

SAFETY INSTRUCTIONS OVERVIEW (continued)

Avoid inclines, if at all possible.

 **WARNING:** Navigating on any incline increases the danger of the 825TKL losing traction or rolling over, especially if the surface is wet. If you lose control, step off immediately to avoid personal injury. Navigation on inclines should be especially slow and turns very gradual. Refer to the incline diagram in the section, “GROUND TRANSPORT”.

Avoid operating adjacent to drop-offs or embankments.

Keep away from tracks to avoid getting crushed.

 **WARNING:** Getting run over by the Track Loader will cause injury.

Always leave the 825TKL parked on a level surface.

 **WARNING:** Do not park on incline. Move the 825TKL to a level surface and set the parking brake located behind the left-hand track motor. Move the handle down to engage the brake.

Do not leave 825TKL unattended with the engine running.

Do not operate the 825TKL near any source of flammable dust or vapors.

 **WARNING:** Sparks from the engine exhaust can cause an explosion or fire in a flammable or explosive atmosphere. Fuel fumes can catch fire or explode.

Do not operate the 825TKL near flames or sparks.

 **WARNING:** Fuel fumes can catch fire or explode.

Shut off engine and allow it to cool before refueling.

 **WARNING:** Fuel fumes can catch fire or explode. Do not smoke when refueling. Do not refuel near a source flames or sparks.

Do not touch the engine, muffler, or any of the hydraulic components until cool.

 **WARNING:** Muffler and engine get hot enough to cause serious burns. For the safety of yourself and others, allow enough time for the engine, muffler, and the hydraulic fluid to cool completely before performing any cleaning or maintenance.

SAFETY INSTRUCTIONS OVERVIEW (continued)

Avoid contact with hydraulic fluid.



WARNING: When machine is operating, hydraulic fluid is under extreme pressure and can get under skin and burn or poison.

Keep others away. If the job site is near a road or pedestrian path, warn and divert both motorized traffic and pedestrians. As appropriate, use traffic flag personnel, signs, cones, and lighting devices to ensure safety.

Only the operator is allowed to stand on the 825TKL.

Never lift the 825TKL over any person at any time.



WARNING: If unit should fall it would crush anybody under it.

We recommend having a fire extinguisher suitable for petrol fires in the operating area.

Attachments can change the center of mass and machine operations.

BATTERY & ELECTRIC STARTER SAFETY INSTRUCTIONS

Shield entire face, especially your eyes, and wear rubber gloves to avoid acid burns whenever doing anything with the battery. Battery caps must be tightly in place if the battery has removable caps.



WARNING: The battery contains sulfuric acid that can cause blindness and severe burns.

Avoid contact with eyes, skin, and clothing. If acid contacts eyes, call 911 immediately and flush eyes with water for 15 minutes or until emergency medical help arrives. If acid contacts skin, flush area with plenty of water. If acid is ingested, drink large quantities of water or milk then follow with milk of magnesia, beaten egg, or vegetable oil, and get medical attention immediately.

Avoid contact with battery components. Wear rubber gloves and wash hands after handling any battery components.



WARNING: Battery posts, terminals, and related accessories contain lead and lead compounds, chemicals known to cause cancer and reproductive harm. Acid can cause blindness and severe burns if leaked from the battery.

Do not charge or jump-start the battery near flames or sparks, or while smoking.



WARNING: Battery fumes are flammable and explosive. Avoid explosion hazard that could blind and burn. Tools and jumper cable clamps can make sparks, so use them with care.

Shield eyes and face, and wear rubber gloves.

BATTERY MAINTENANCE is in the OWNER'S MANUAL.

825TKL OPERATING INSTRUCTIONS

READ SAFETY INSTRUCTIONS BEFORE OPERATING! Both the SAFETY INSTRUCTIONS and OPERATING INSTRUCTIONS are in this manual.

Be sure that the engine oil and fuel, and the machine hydraulic fluid are all at proper levels before starting the engine.

STUDY AND UNDERSTAND CONTROLS BEFORE BEGINNING OPERATION.

CONTROLS

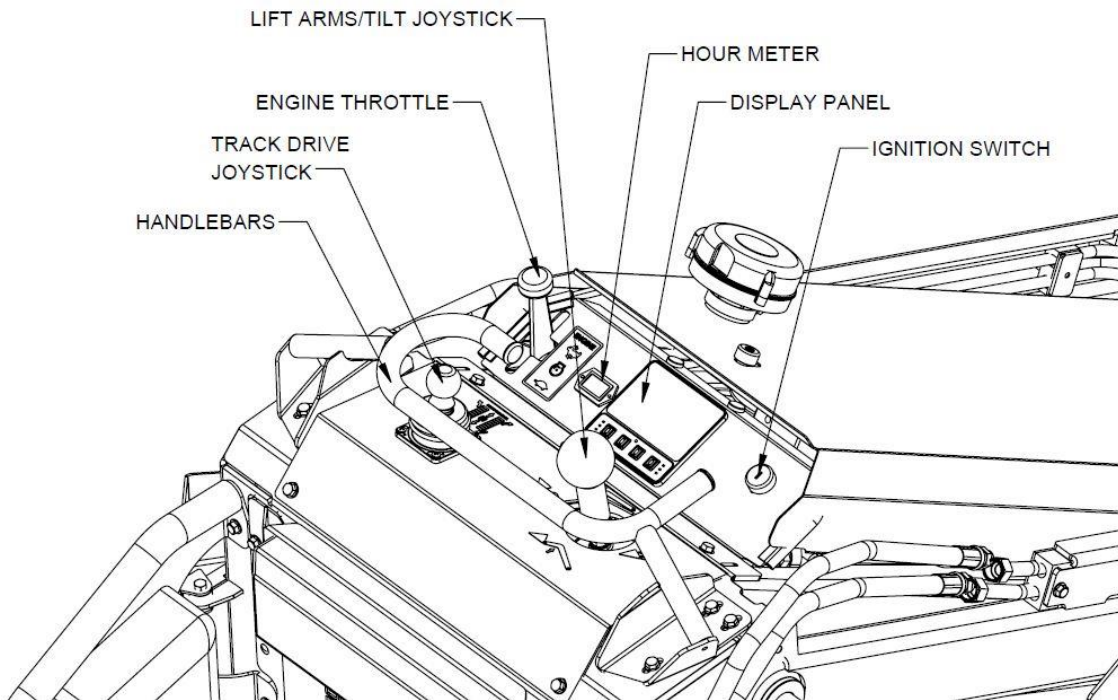

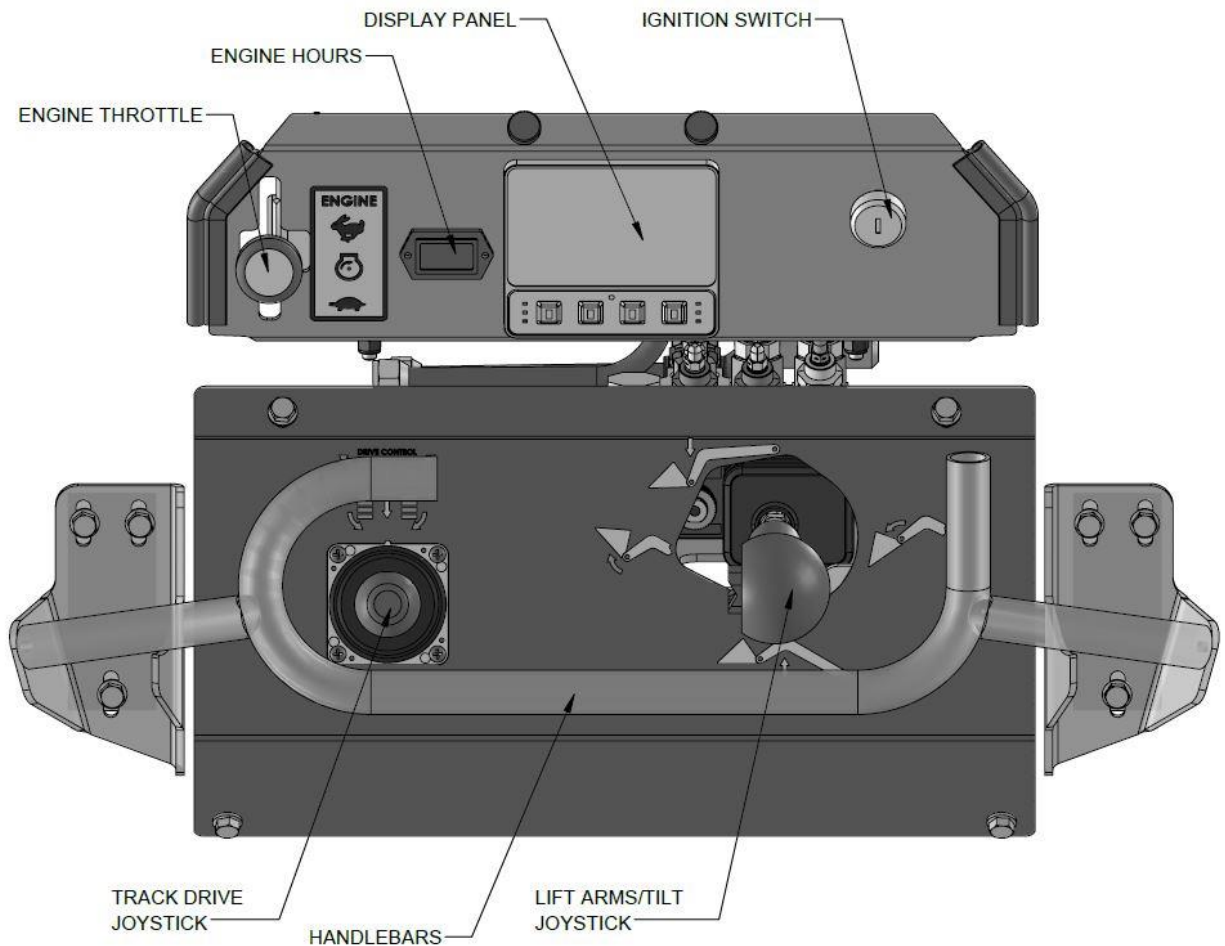

ENGINE START UP PROCEDURE

Your 825TKL is setup with an automatic glow plug warmer. If the coolant temperature is below 140F°, the glow plugs will warm for 5-10 seconds.

1. Insert key into ignition
2. Set throttle at low idle
3. Turn key to the first setting (ACC). The glow plugs will warm if necessary
4. Turn key to “START” position to engage starter. Engine should fire within a few seconds. Do not run the starter more than 20 seconds at a time. This may damage the starter motor.
5. Warm up the engine at a medium idle without load

Check to make sure the oil pressure light goes off. If the oil pressure light remains on, turn engine off immediately and determine the cause.

ENGINE SHUT DOWN PROCEDURE

1. Return the speed control lever to idle
2. Turn the key off

Allow engine to cool before refueling.



WARNING: Fuel fumes can catch fire or explode. Do not smoke or allow flames or sparks in the area.

Do not touch the engine, muffler, or any of the hydraulic components until cool.



WARNING: Muffler and engine get hot enough to cause serious burns. For the safety of yourself and others, allow enough time for the engine, muffler, and the hydraulic fluid to cool completely before performing any cleaning or maintenance.



See the Engine Manual from Kubota included with the machine for more engine instructions.

Only operate the 825TKL outdoors and avoid breathing engine exhaust and fumes.

COLD WEATHER OPERATIONS: Before operating in cold weather, refer to the Engine Owner's Manual for recommended engine oil. Do not spray starting fluid into the air cleaner as engine damage could result. If the machine is operated at temperatures below +32°F (0°C) then changing the hydraulic fluid to ISO 46 is recommended. If you do not want to change the hydraulic fluid but want to operate the machine at temperatures below +32°F (0°C), then do the following:

- Warm up engine at a low speed.
 - Gradually increase engine speed, allowing **30 minutes for the hydraulic fluid to warm up.**
- Reduce the engine speed if the hydraulic pump whines. Pump noise may indicate a lack of hydraulic fluid flow that could damage the pump.

For frequent starts below 18°F consult your Barreto Manufacturing, Inc. dealer.

DRIVING PROCEDURE

1. Follow engine start up procedure.
2. Securely grasp the handle surrounding the control levers.
3. The left-hand lever controls the track system and speed. Increasing the lever movement forward or backwards will increase the speed of the unit.
4. Moving the left-hand lever left or right will drive the tracks in that direction
5. The right lever controls the lift arms and tilt of the attachment plate. Pulling the lever back will raise the arms, pushing forward will lower the arms. Moving the lever left will tilt the attachment plate upward, moving it to the right will tilt the attachment plate downward or away from the operator.
6. Pushing the right-hand lever fully forward will enable the float action of the lift arms, allowing the attachment to follow the contour of the ground.

NOTE: the 825TKL ride platform contains an Operator Presence Switch which will disable all machine functions if the operator steps off the platform. The operator must be standing on the platform for all driving, lift arm or tool functions to operate.

OPERATIONAL INCLINES

Do not operate the 825TKL on a side hill greater than 20°. Doing so may cause the unit to tip over and cause damage to the operator and machine.

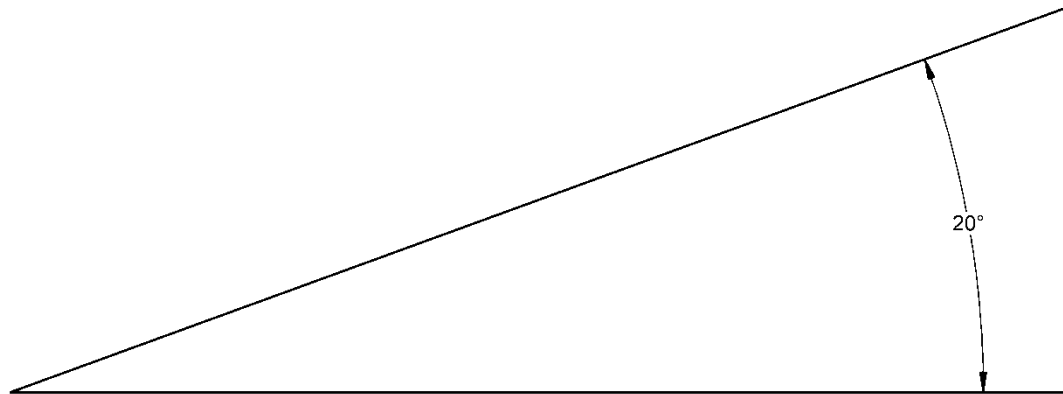

ATTACHMENTS

The 825TKL is designed to use a wide variety of industry-standard attachments from multiple manufacturers. The attachment system consists of a mount plate connected to the lift arms at the front of the machine. This plate also contains two lock pins to prevent the attachment from disconnecting while in use.

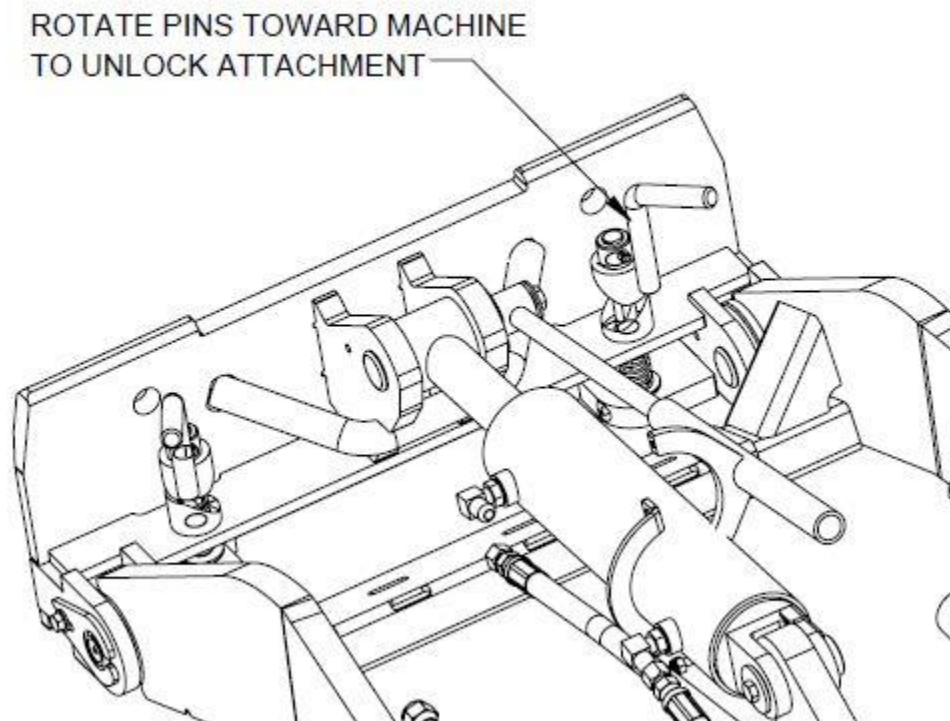

To connect to an attachment, tilt the attachment plate down toward the desired tool and drive the attachment plate into the pocket on the attachment. Once the attachment plate is fitted to the pocket,

tilt the attachment plate upward to until the plate fully rests against the tool. Lock the two lock pins in place using the levers attached to the lock pins. Once the attachment is fully secured, return to the ride platform.

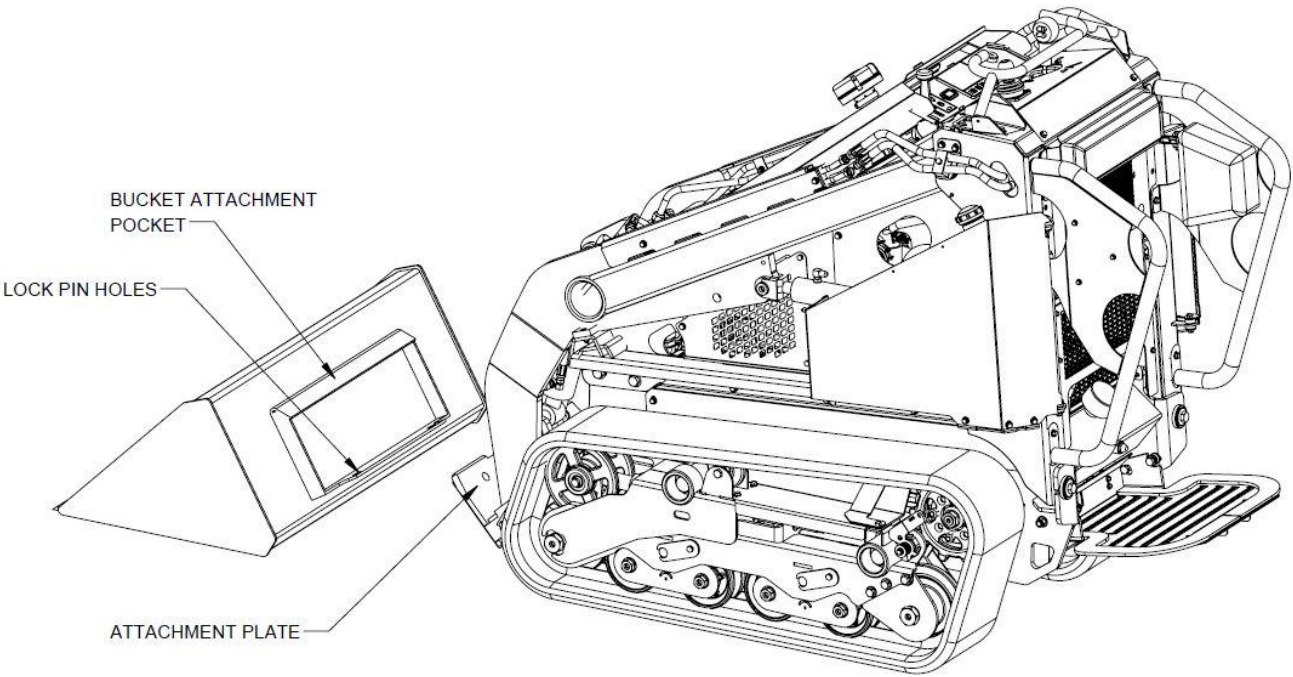

DISPLAY PANEL FEATURES

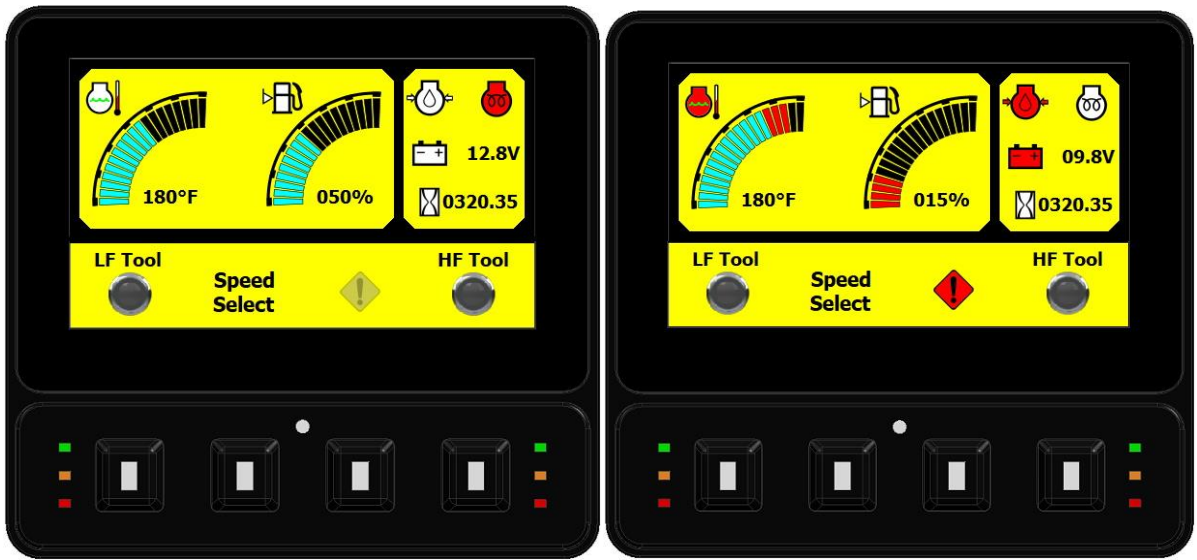

The display panel shows important information or warnings regarding the machine and engine operation. The display panel also contains several buttons that will need to be used for the auxiliary tools to be enabled. Normal operational information will be displayed in Blue, while warnings will be displayed in Red.

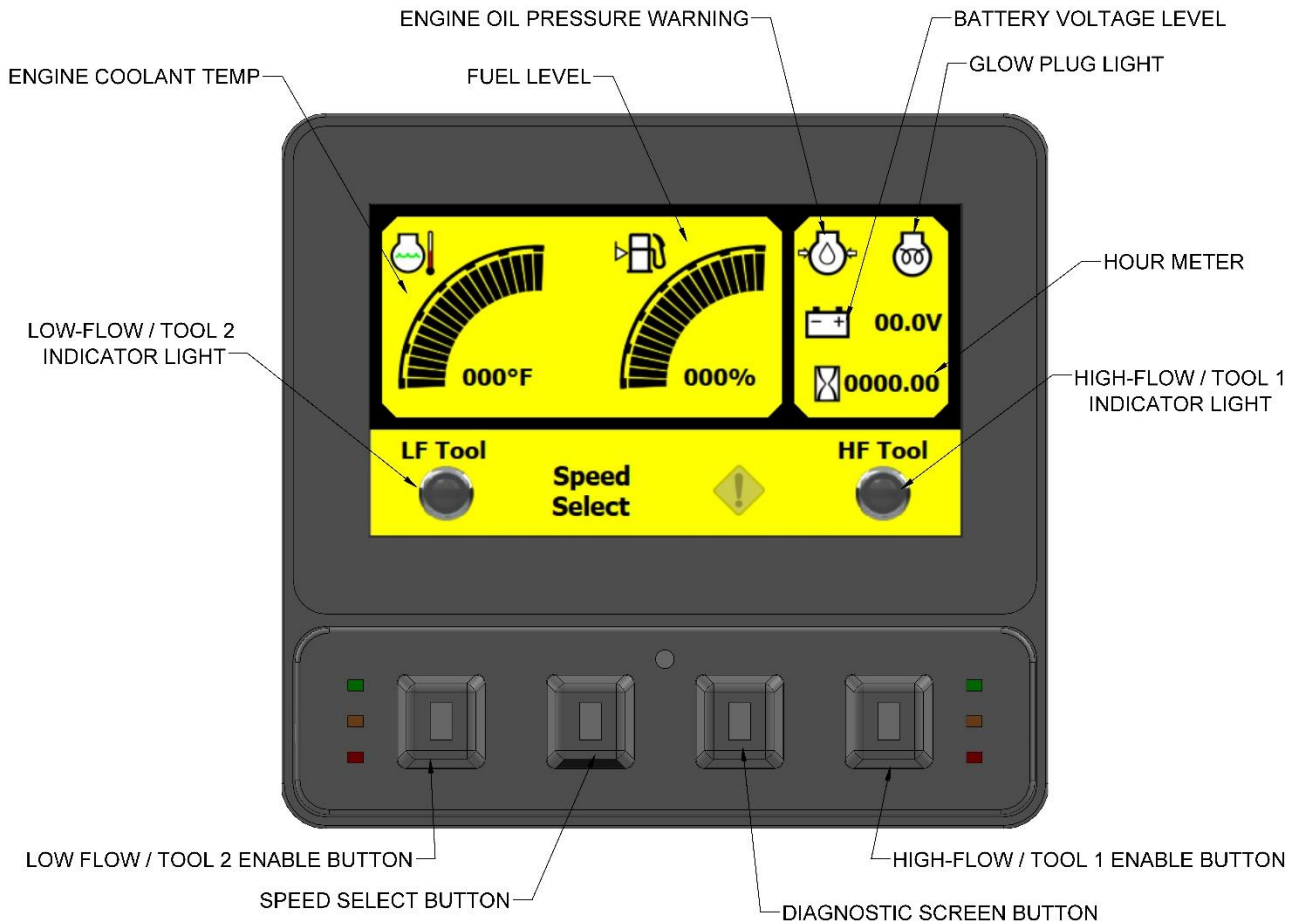

SPEED SELECTION

The track drive speed can be selected from the display to allow better control in tight spaces or while using attachments. To select the operating speed of the track drive, press the “Speed Select” button on the display, then press the button again to cycle through the speed drive options.

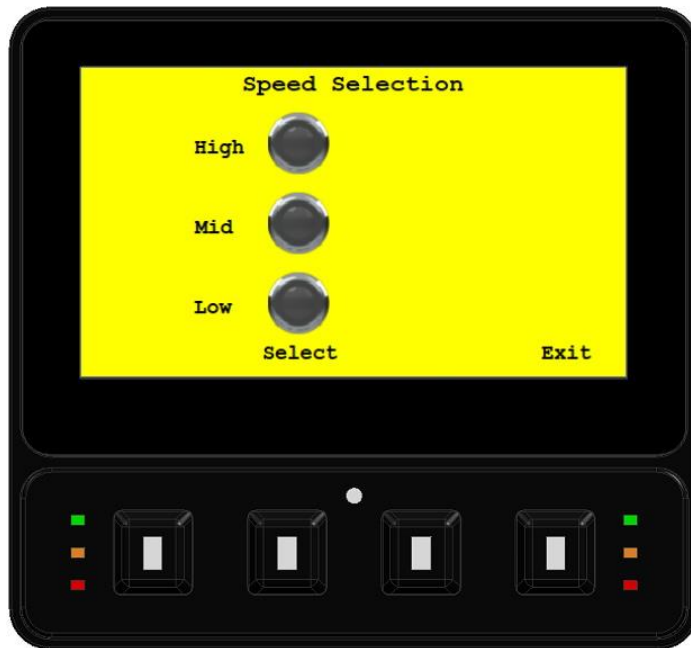

TIP-OVER PROTECTION

In the event of a Tip-Over situation, the machine’s incline sensor will shut off the fuel pump and kill the engine. You will see the following images on the screen. The operator will need to call the rental center the machine came from and get Tip-Over code from the owner. Use the display buttons to enter the code to allow the machine to start again.

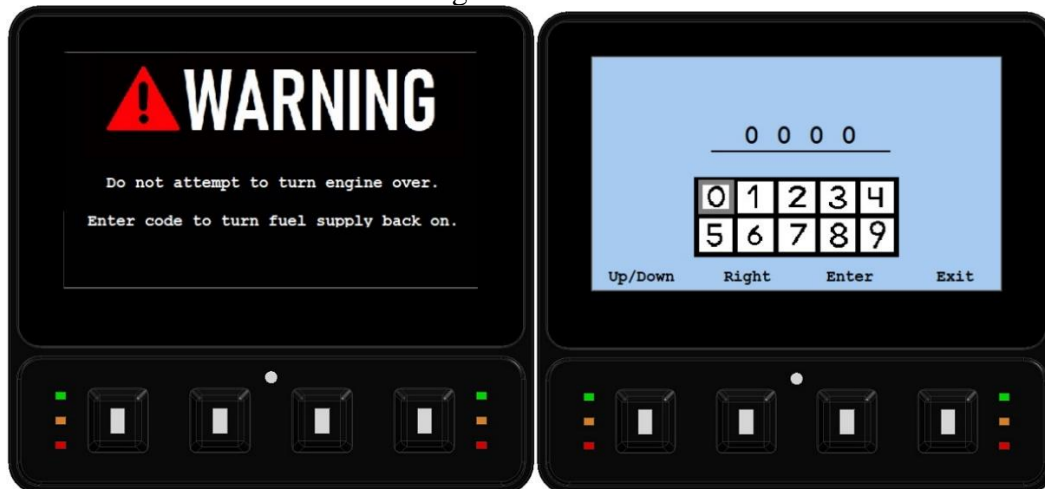

TOOL HOSE ATTACHMENT

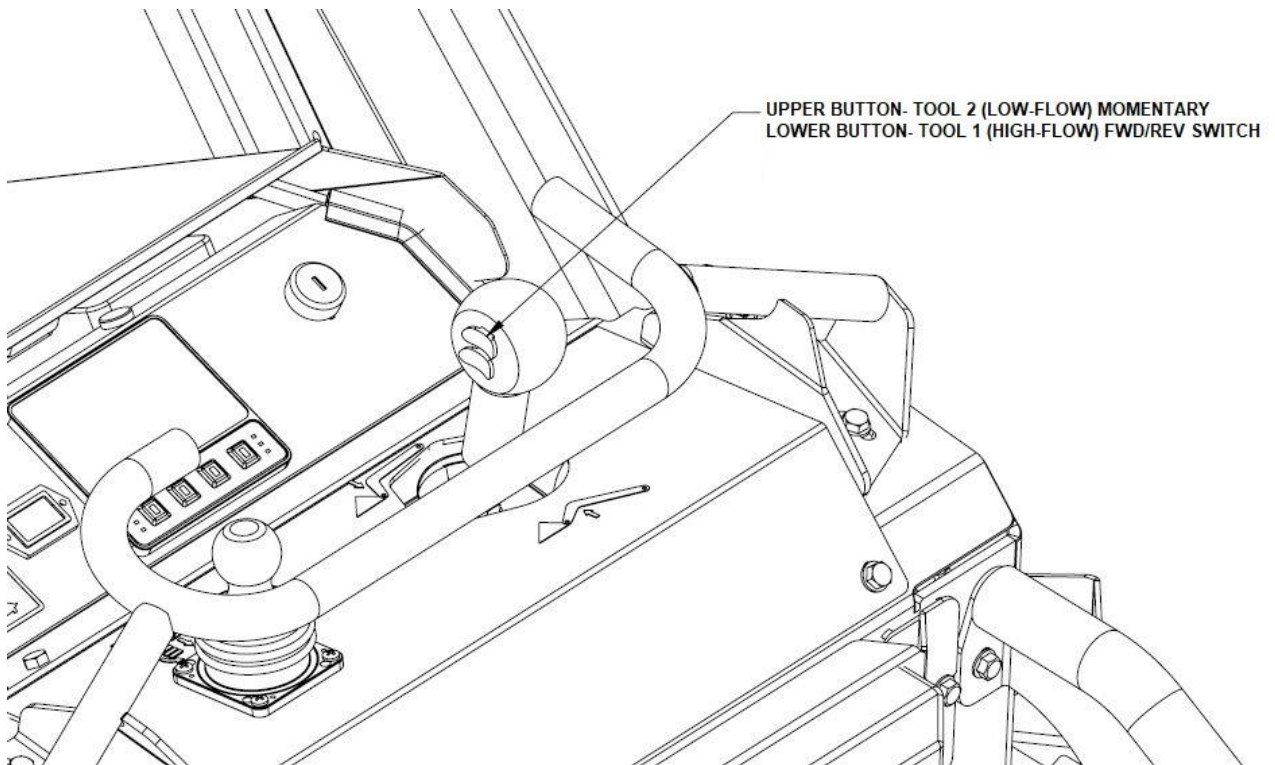
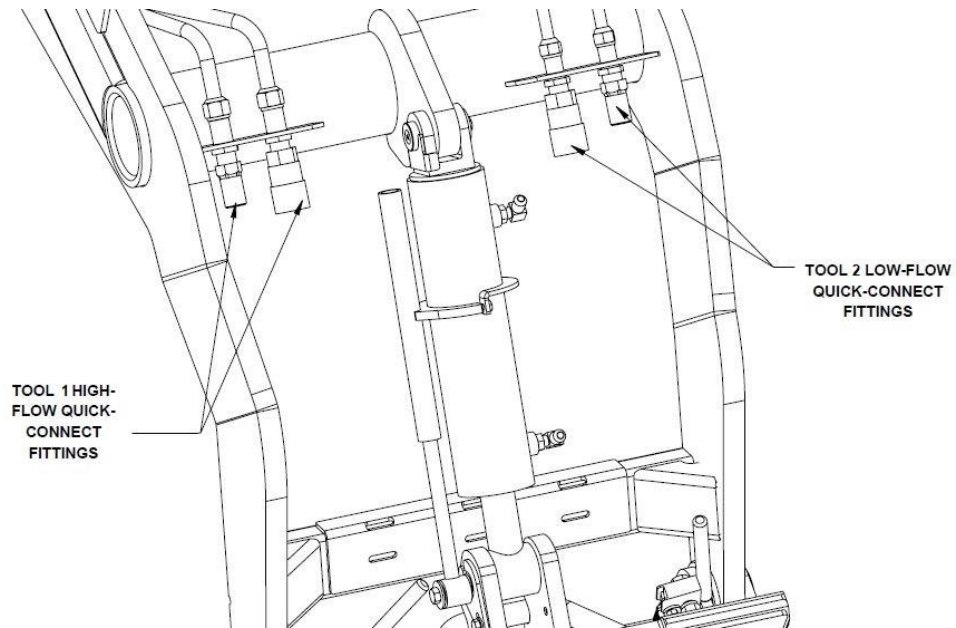

LOW FLOW ATTACHMENTS (LF Tool, Tool 2)- Attachments with Grapples or smaller, secondary cylinders will use the Low-Flow Auxiliary quick-connect fittings.

To enable, press the “**LF Tool**” button on the left side of the display panel. This will allow the operator to use the Low-Flow Auxiliary lines. The lift arm joystick has two buttons controlled by the operator’s right thumb. The upper button controls TOOL 2. The operator can then switch the tool

flow forward or reverse. The TOOL 2 switch can be pressed FWD or REV but will spring to OFF when not pressed.

NOTE: If the operator steps off the ride platform, the operator must press the “**LF Tool**” button again to enable the tool. The presence switch on the ride platform will disable the tool function if operator steps off the platform.

HIGH-FLOW ATTACHMENTS (HF Tool, Tool 1)- Tools such as a Trenchers, Augers, Mowers and similar attachments will have a hydraulic motor. These attachments will need to be attached to the High-Flow auxiliary quick-connect fittings on the right side of the lift arms.

To enable **TOOL 1**, press the “**HF Tool**” button on the right side of the display panel. This will allow the operator to use the High-Flow Auxiliary lines. The lift arm joystick has two buttons controlled by the operator’s right thumb. The lower button controls TOOL 2. The operator can then switch the tool flow forward or reverse. The TOOL 1 switch will stay locked in FWD, REV or OFF when not pressed.

NOTE: If the operator steps off the ride platform, the operator must press the “**HF Tool**” button again to enable the tool. The presence switch on the ride platform will disable the tool function if operator steps off the platform.

JUMP STARTING ENGINE WITH ELECTRIC STARTER

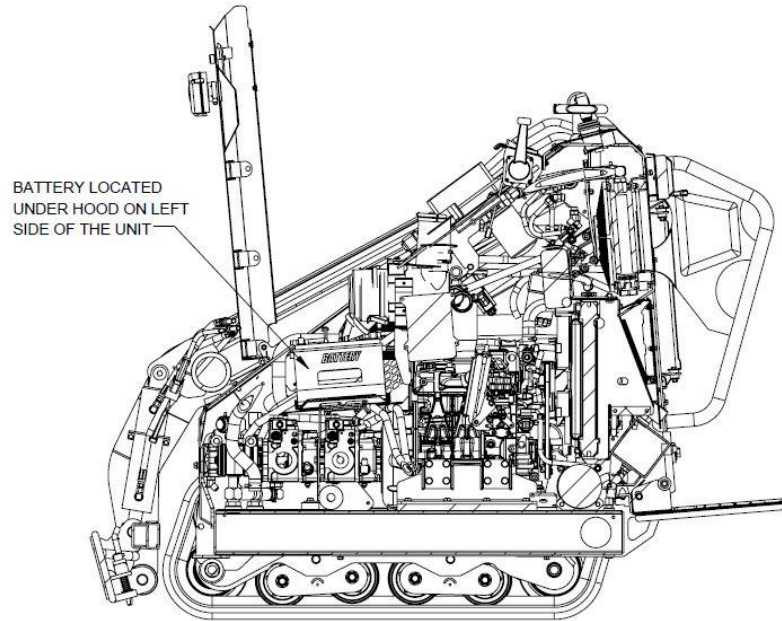

Shield entire face, especially your eyes, and wear rubber gloves to avoid acid burns whenever doing anything with the battery. Battery caps must be tightly in place if the battery has removable caps.

⚠ WARNING: The battery contains sulfuric acid that can cause blindness and severe burns. Avoid contact with eyes, skin, and clothing. If acid contacts eyes, call 911 immediately and flush eyes with water for 15 minutes or until emergency medical help arrives. If acid contacts skin, flush area with plenty of water. If acid is ingested, drink large quantities of water or milk then follow with milk of magnesia, beaten egg, or vegetable oil, and get medical attention immediately.

Avoid contact with battery components. Wear rubber gloves and wash hands after handling any battery components.

⚠ WARNING: Battery posts, terminals, and related accessories contain lead and lead compounds, chemicals known to cause cancer and reproductive harm. Acid can cause blindness and severe burns if leaked from the battery.

Do not jump start the battery near flames or sparks, or while smoking.

⚠ WARNING: Battery fumes are flammable and explosive. Avoid explosion hazard that could blind and burn. Tools and jumper cable clamps can make sparks, so use them with care. Shield eyes and face, and wear rubber gloves.

Do not jump-start or charge a battery that is frozen or low on electrolyte.

IMPORTANT: Use only a 12-volt system for jump-starting. Never allow the vehicle used to jump-start to contact the disabled machine. If the vehicles contact, a spark may occur when the positive jumper cable is connected or disconnected. If equipped with battery caps, they must be in place and tight to reduce risk of battery explosion.

JUMP STARTING PROCEDURE:

1. Turn ignition switch to OFF. Open engine hood to expose battery location.
2. Connect jumper cables in the following order:
 - a) Clamp one RED cable end to the discharged battery POSITIVE (+) terminal.

- b) Clamp the other end of the RED cable to the booster battery POSITIVE (+) terminal.
 - c) Clamp one BLACK cable end to the booster battery NEGATIVE (-) terminal.
 - d) Clamp the other end of the BLACK cable to the frame of machine with the discharged battery, away from battery.
3. Start the engine.
 4. Disconnect the cables in reverse order of connection and cover each jumper cable terminal. To avoid sparks near the battery, never disconnect the red jumper cable without first disconnecting the black jumper

EMERGENCY TOWING

In case of engine failure there is a provision that allows the 825TKL to be towed a short distance.

The 825TKL tracks are driven by a set of tandem hydrostatic pumps. The front pump drives right track, and the other pump drives left track. The drive pump bypass valves may be opened to allow the machine to be towed.

- Set the parking brake if on a slope to prevent rolling. It is located behind the left-hand track motor. Move the handle down to engage the brake.



WARNING: Navigating on any slope increases the danger of the trencher losing traction or rolling over, especially if the surface is wet. Stay out of the way to avoid personal injury.

- Loosen (do not remove) the by-pass plugs two complete turns counterclockwise. See diagram for location of plugs.
- Disengage the parking brake by moving the handle up.
- The machine may be towed short distance (1/8 mile or 1/4km max) at slow speed, 2 mph or 200 feet per minute maximum (3kph or 60m per min).
- After towing, close both by-pass valves by closing the plugs with 10 foot-pounds torque.
- Use a trailer or truck for road transport.

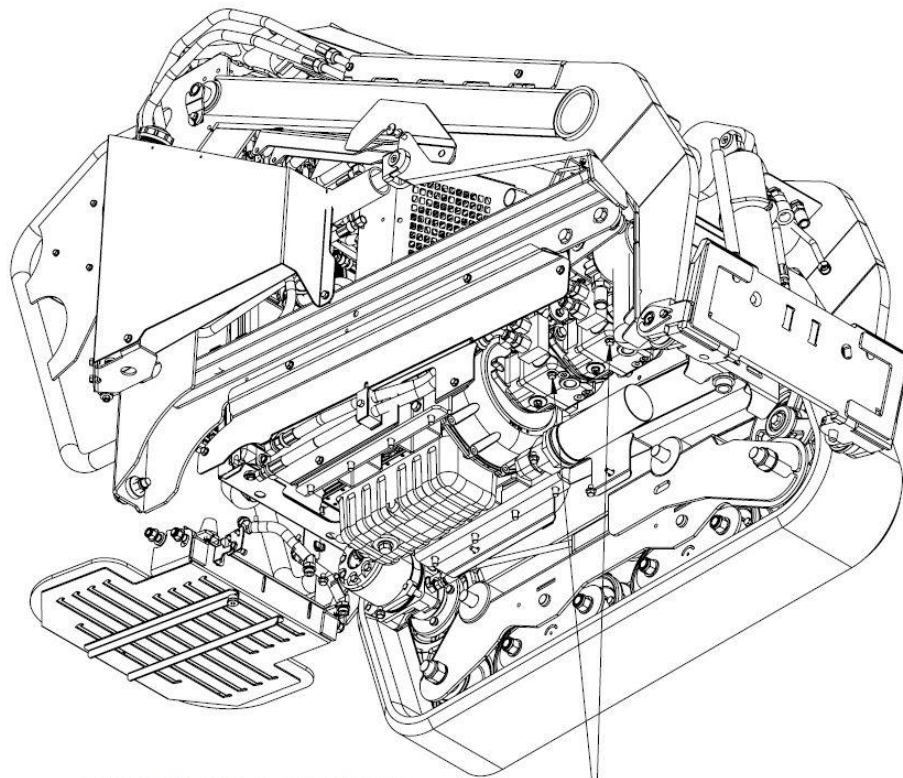

BYPASS PORT LOCATIONS
(SOME ITEMS HIDDEN TO BETTER SHOW LOCATION)

DETAILED BYPASS LOCATION (Engine rotated sideways to better illustrate location)

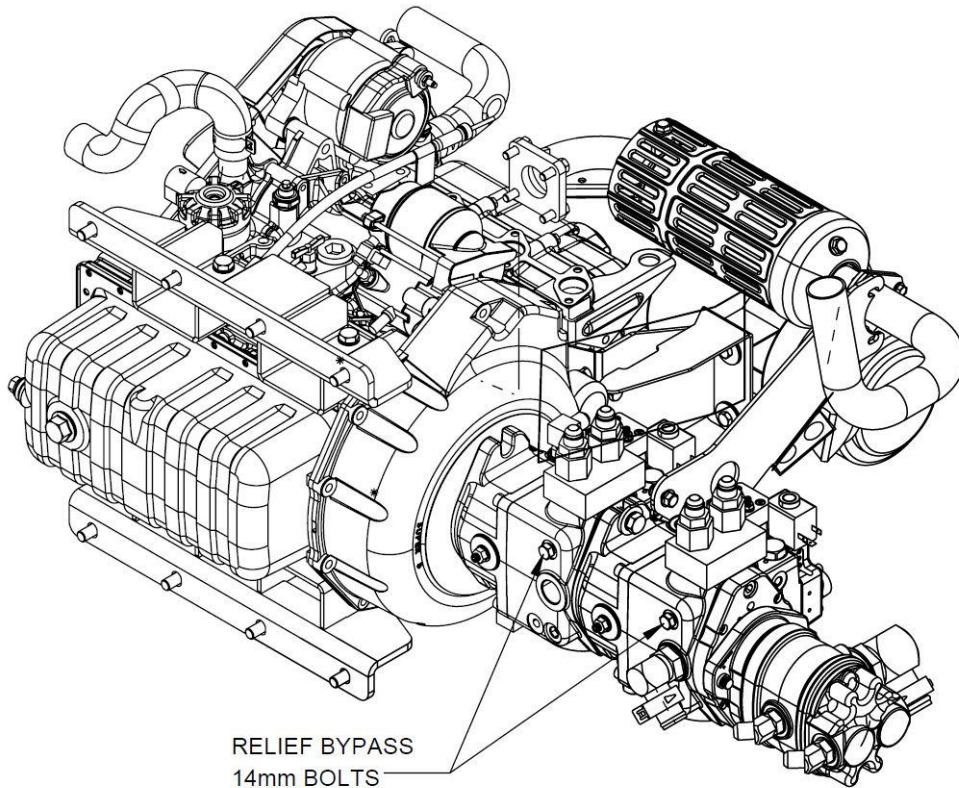

ROAD TRANSPORT OF THE 825TKL

The 825TKL must be transported on a trailer with a minimum weight rating of 3500lbs

Refer to the following checklist before towing:

- Towing vehicle should have the correct size ball. Be sure it is in good repair and securely fastened to the vehicle.
- Securely fasten the hitch to the ball by tightening the hitch nut.
- Thread the safety chain through the loop in the hitch nut handle to prevent it from vibrating loose while towing.
- Attach the safety chain to the towing vehicle in such a way that it cannot come off accidentally.
- Check the hitch-to-ball connection after driving a few blocks and re-tighten if necessary.

Always exercise extreme caution and allow extra clearance while towing a trailer. **DRIVE SAFELY!**

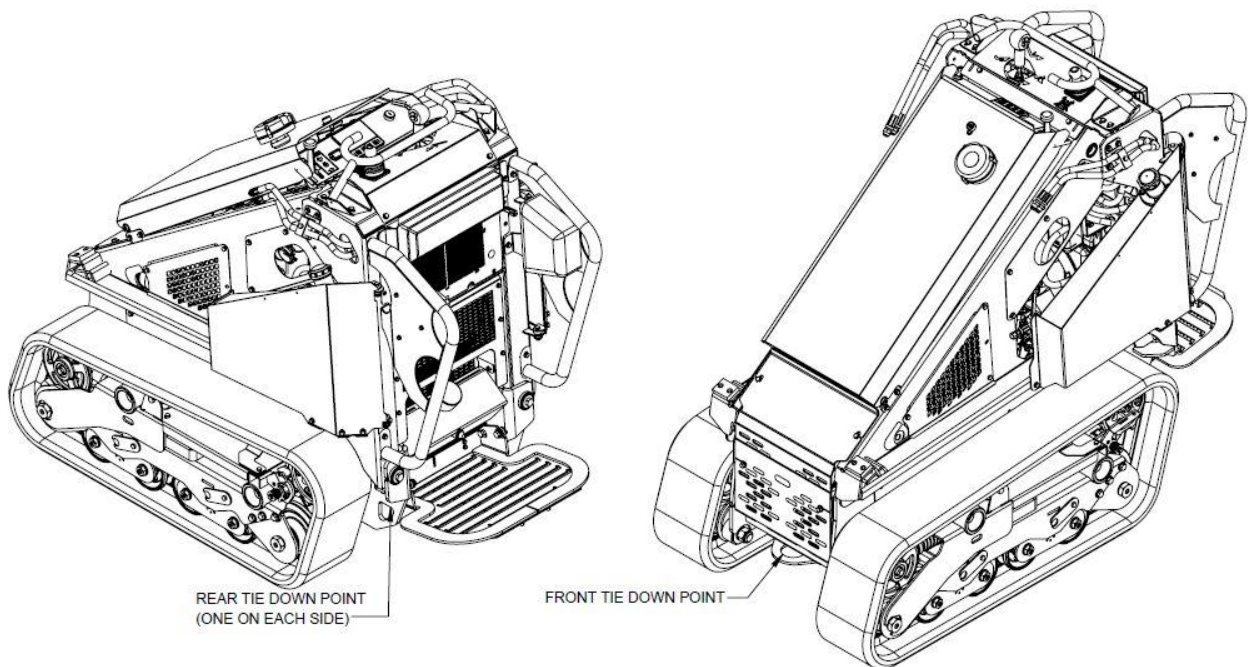

LOADING PROCEDURE:

1. Trailer and vehicle should be located on level ground before loading the 825TKL
2. If the trailer ramp angle is greater than 10°, the 825TKL should be loaded in reverse to allow the bucket or attachment to prevent the unit from tipping forward.
3. Drive the machine onto the trailer and position the machine to provide adequate tongue weight on the towing vehicle (tongue weight should be 10-20% of total towing weight).
4. Raise lift arms to allow access to the tie down point at the front of the 825TKL body, between the tracks.
5. Loop a chain through the front tie down point and secure chain with a quick-link or chain binder.
6. Loop a second chain through **both** rear tie down points and secure with a chain binder.
7. Lower the lift arms down onto the chain securing the front of the unit and apply a small amount of downward pressure on the chain.
8. Shut down machine following the shutdown procedure.

UNLOADING PROCEDURE

1. Position the tow vehicle and attached trailer on level ground.
2. Remove all chains or straps connecting the 825TKL to the trailer D-rings
3. Start the engine using the ENGINE START UP PROCEDURE.
4. Keep the bucket or attachment low to the ground to prevent the unit from tipping forward while unloading
5. Drive the 825TKL slowly down the trailer or trailer ramps. Continue backward until tracks are completely on the ground.

OPERATOR PREPARATION

Each operator must:

- Become familiar with the controls and operation of the trencher, preferably under the supervision of an experienced operator.
- Be at least 21 yrs. of age and be mentally and physically capable of operating the trencher safely.
- Have studied the SAFETY AND OPERATING INSTRUCTIONS in this manual.

PERSONAL PROTECTION: For safety, trencher operator should wear personal protection equipment. Keep observers at a safe distance.

Wear safety eye goggles and a hard hat while operating or observing!

Wear safety boots and gloves. Wear close-fitting clothing. Contain long hair. Do not wear jewelry. Wear reflective clothing if working near traffic.

Wear adequate hearing (ear) protection while operating or observing.

 **WARNING:** Exposure to loud noise is cumulative and may permanently damage your hearing.



DETERMINE LOCATION OF UNDERGROUND UTILITIES

OSHA CFR 29 1926.651 requires that the estimated location of underground utilities be determined before beginning excavation or an underground drilling operation. When the actual excavation or bore approaches an estimated utility location, the exact location of the underground installation must be determined by a safe, acceptable and dependable method. If any utility cannot be precisely located, the appropriate utility company must shut it off.

Call before you dig. If you do not call, you may cause an accident; suffer injuries or death; cause interruption of services; damage the environment; and/or incur project delays. Expect to be held liable for any damages caused, if you fail to call.



DANGER: Buried electric cables or gas lines can cause serious injury or death if struck with trenching attachments. Always determine location of utilities before trenching.



WARNING: Fiber optic cables convey laser light that can injure your eyesight.

To locate utilities before trenching call 811 or 1-888-258-0808 (US. or Canada). This free service will provide a “One-Call” number for the geographic area that you select. Before you start any digging project, be sure to call the local One-Call system in your area and any utility company that does not subscribe to the One-Call system. The One-Call representative will notify participating utility companies of your proposed digging activities. Utilities will then mark their underground facilities by using the following international marking codes:

| | |
|-------------|--------------------------------------|
| Red | Electric |
| Yellow | Gas, oil, or petroleum |
| Orange | Communication, telephone, television |
| Blue | Potable water |
| Green/brown | Sewer |
| White | Proposed excavation |
| Pink | Surveying |

For areas not represented by One-Call Systems International, contact the appropriate utility companies to locate and mark the underground installations. Do not rely on visual evidence of underground utilities such as manhole covers or electrical drop boxes...**CALL!**



**Know what's below.
Call before you dig.**

WORK SITE ASSESSMENT

Examine the work area for any conditions or obstructions that may inhibit operation or create a safety hazard for the operator or others. Use the information in this manual combined with good judgment to identify any hazards to avoid.

In addition to calling to DETERMINE LOCATION OF UNDERGROUND UTILITIES (see previous section for details) the operator and/or job foreman should visually inspect the work site. Look for electrical drop boxes; notices of underground placements; manhole covers; recent trenching activity; any evidence of possible underground placements; banks; overhangs; drop-offs; rocks; tree limbs; wire; uneven terrain; any existing trenches or holes; and toxic ground conditions.

Only operate trencher outdoors and do not breathe engine exhaust and fumes.



WARNING: Engine exhaust contains carbon monoxide gas that is toxic. Breathing it can cause unconsciousness and death.

Do not operate trencher near any source of flammable dust or vapors.



WARNING: Sparks from the engine exhaust can cause an explosion or fire in a flammable or explosive atmosphere. Fuel fumes can catch fire or explode.

Allow adequate side and overhead clearances between trencher and any objects such as buildings, fences, and trees.

Adequate lighting is required, daylight or artificial, for safe operation of the trencher.

Keep others away. If the job site is near a road or pedestrian path, warn and divert both motorized traffic and pedestrians. As appropriate, erect barriers, use traffic flag personnel, signs, cones, and lighting devices to ensure safety.

CONTACT WITH UNDERGROUND UTILITIES

After LOCATING UNDERGROUND UTILITIES and performing the WORK SITE ASSESSMENT, accidental digging attachments contact with a buried utility might still occur. If it does, stop digging and call 911 for help.

If you cut a wire or cable, assume that you do not know what kind it is. It may be electrical or any one of several communication lines: telephone, television, or fiber optic. In any case, do not touch it or even look at the ends of it. Stop digging and call 911 for help. Do not dig any more until the appropriate utility company has assessed the situation, taken appropriate action, and informed you that is safe to proceed.

If you strike a pipe, it could be gas, oil, petroleum, water, or sewer. In any case, stop digging, shut off the engine, and evacuate the area immediately. Call 911 for help.

Electrical wires or cables: If you think that you may have severed electrical wires, stop digging and call 911 for help. Keep yourself and other people away from the area.



DANGER: An electric shock could kill you. Assume that any severed wire or cable is HOT with voltage and do not touch it!

Gas lines: If you think that you may have struck a gas line, shut off the engine and evacuate the area immediately. Call 911 for help.



DANGER: A gas explosion could kill you. Sparks will likely occur from the dig chain scraping the metal pipe. If gas leaks out an explosion could easily occur.

Fiber optic cables: If you think that you may have severed a fiber optic cable, do not touch or even look at the ends of it.



WARNING: Fiber optic cables convey laser light that can injure your eyesight. Call 911 for help.